

2ME

Aluminium gear motors

Technical Catalogue

E0.120.0219.02.00IM04

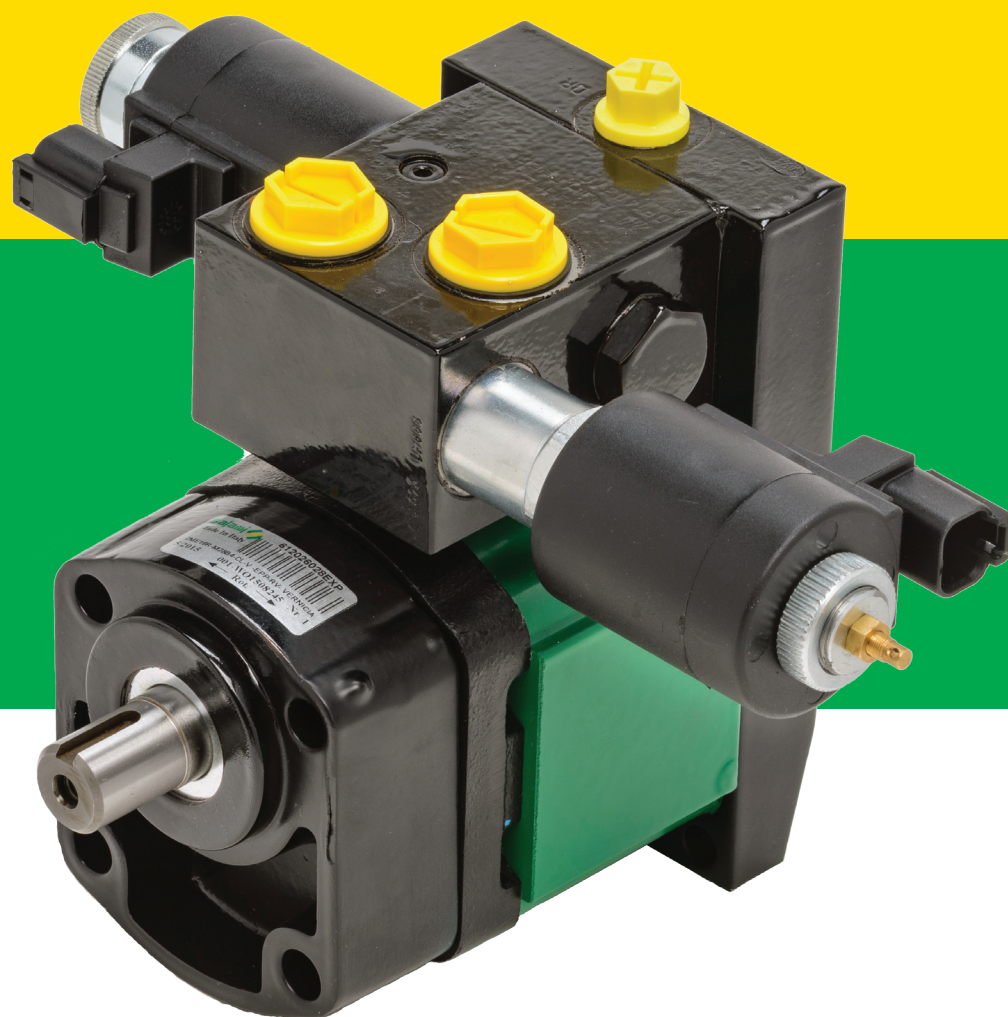

GEAR MOTORS

- Displacements from 2.8 cm³/rev to 73.4 cm³/rev (*from 0.17 cu.in./rev to 4.48 cu.in./rev*).
- Rated pressure up to 250 bar (3625psi).
- Speed up to 4500 rpm.
- Flanges, shafts and ports for ISO, DIN and SAE standards.
- Available in uni and bi-directional version for all the sizes, displacements and configurations.
- High volumetric efficiency thanks to an innovative design and an accurate control of machining tolerances.
- Axial compensation achieved by the use of floating bushes that allow high volumetric efficiency throughout the working pressure range.
- DU bearings to ensure high pressure capability.
- 12 teeth integral gear and shaft.
- Aluminium body.
- Cast iron flange and cover.
- Double shaft seals in all motor series. The one which faces the internal side is reinforced.
- Nitrile seals as standard and Viton seals in high temperature applications.
- Available with different valves and circuit configurations built-in rear cover.
- All motors are hydraulically tested after assembly to ensure the highest standard performance.

WORKING CONDITIONS

- Max pressure drain	20 bar (290 psi)
- Minimum operating fluid viscosity	12 mm ² /sec
- Permitted viscosity range	12 - 800 mm ² / sec
- Recommended viscosity range	20 - 80 mm ² / sec
- Permitted viscosity for starting	2000 mm ² / sec
- Fluid operating temperature range	-20 to 80 °C
- Fluid operating temperature range with FPM seals	-15 to 110°C
- Fluid operating temperature range with HNBR seals*	-30 to 110°C
- Hydraulic fluid	Mineral oil according to DIN 51524. Other hydraulic fluids on request.

*Available on request

DEFINITION OF PRESSURES

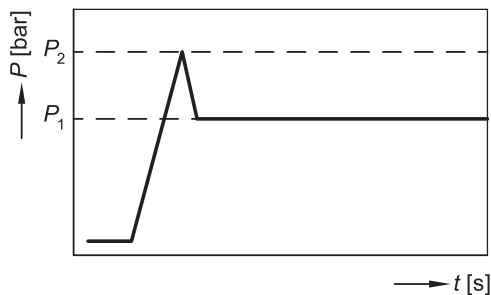

P_1 max. continuous pressure
 P_2 starting pressure (depending on the application, this must be taken into consideration when setting the pressure of the hydraulic system's pressure-relief valve).

EO.100.0821.02.001M03



DRIVE SHAFTS

Radial and axial loads on the shafts must be avoided since they reduce the life of the unit. In order to avoid misalignment during the assembly with the primary engine, a connection with "Oldham" coupling (or coupling having convex toothed hub) is recommended.

ROTATION

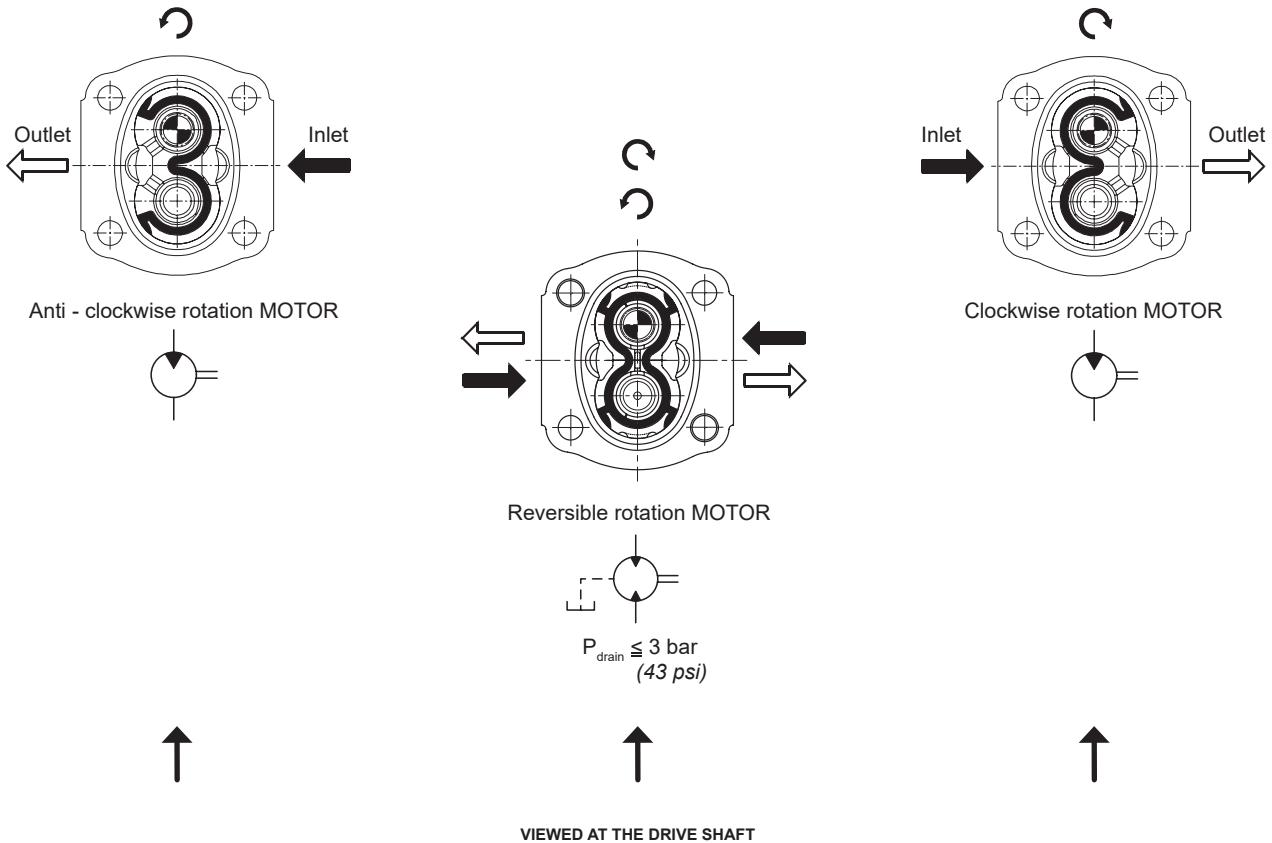

HYDRAULIC PIPE LINE

To calculate hydraulic pipe line size, the designer can use; as an approximate guide, the following fluid speed figures:

From 6 to 10 m/sec on pressure pipe line

From 19.7 to 32.8 ft/sec on pressure pipe line

The lowest fluid speed values in pipe lines is recommended when the operating temperature range is high and/or for continuous duty.

The highest value is recommended when the temperature difference is low and/or for intermittent duty.

In case of reversible motor allowance must be made to ensure the motor is not drained, through the case drain, when stationary.

FILTRATION INDEX RECOMMENDED

Working pressure	>200 bar/2900 psi	<200 bar/2900 psi
Contamination class NAS 1638	9	10
Contamination class ISO 4406	19/18/15	20/19/16
Achieved with filter $\beta_x=75$	15 μm	25 μm

COMMON FORMULAS FOR MOTORS

Based on SI units

Input flow: $Q = \frac{V \cdot n}{1000 \cdot \eta_v}$ l/min

Output torque: $M = \frac{V \cdot \Delta p \cdot \eta_m}{20 \cdot \pi}$ Nm

Output power: $P = \frac{M \cdot n}{9550} = \frac{Q \cdot \Delta p \cdot \eta_t}{600}$ kW

Variables: SI units [US units]

Based on US units

Input flow: $Q = \frac{V \cdot n}{231 \cdot \eta_v}$ [US gal/min]

Output torque: $M = \frac{V \cdot \Delta p \cdot \eta_m}{2 \cdot \pi}$ [lbf·in]

Output power: $P = \frac{M \cdot n}{63\,025} = \frac{Q \cdot \Delta p \cdot \eta_t}{1714}$ [hp]

LEGENDA

- V = Displacement cm³/rev [in³/rev]
- P_{out} = Outlet pressure bar [psi]
- P_{in} = Inlet pressure bar [psi]
- ΔP = $P_{out} - P_{in}$ (system pressure) bar [psi]
- n = Speed min⁻¹ (rpm)
- η_v = Volumetric efficiency
- η_m = Mechanical efficiency
- η_t = Overall efficiency ($\eta_v \cdot \eta_m$)

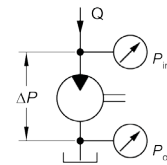

IDENTIFICATION LABEL



Made in Italy

2ME11,3D-P28P1

001-WO1-[-]-[-]-[-]-[-]

612014017

2/2021

Nr 1

Salami Manufacturing Part Number

Manufacturing Date, Month and Year

Batch Serial Number

Rot. →

Unit Rotation

Build Order Number (for Salami management)

EO.100.0821.02.001M03



TECHNICAL DATA

GROUP 1.5 - E SERIES	Displacement		Max. continuous pressure P ¹		Max. starting pressure P ²		Max. speed at P ²	Min. speed at P ¹
	cm ³ /rev	cu.in/rev	bar	psi	bar	psi	rpm	
1.5ME - 2.8	2.8	0.17	250	3625	270	3915	4500	700
1.5ME - 3.5	3.5	0.21	250	3625	270	3915	4500	700
1.5ME - 4.1	4.1	0.25	250	3625	270	3915	4000	700
1.5ME - 5.2	5.2	0.32	230	3335	250	3625	4000	700
1.5ME - 6.2	6.2	0.38	230	3335	250	3625	3600	600
1.5ME - 7.6	7.6	0.46	200	2900	220	3190	3300	600
1.5ME - 9.3	9.3	0.57	180	2610	200	2900	3000	600
1.5ME - 11	11	0.67	170	2465	190	2755	3000	600

GROUP 2 - E SERIES	cm ³ /rev	cu.in/rev	bar	psi	bar	psi	rpm	
2ME - 4.5	4.6	0.27	250	3625	280	4060	4000	600
2ME - 6.5	6.5	0.4	250	3625	280	4060	4000	600
2ME - 8.3	8.2	0.5	250	3625	280	4060	3600	500
2ME - 10.5*	10.6	0.65	250	3625	280	4060	3500	500
2ME - 11.3	11.5	0.68	250	3625	280	4060	3500	500
2ME - 12.5*	12.7	0.77	250	3625	280	4060	3400	500
2ME - 13.8	13.8	0.84	250	3625	280	4060	3400	500
2ME - 16	16.6	1.01	250	3625	280	4060	3200	450
2ME - 19	19.4	1.15	220	3190	240	3480	3200	450
2ME - 22.5	22.9	1.37	200	2900	220	3190	3000	450
2ME - 26	26.6	1.62	180	2610	200	2900	2850	450

*Available for quantity

GROUP 2.5 - B SERIES	cm ³ /rev	cu.in/rev	bar	psi	bar	psi	rpm	
2.5MB - 16	16	0.97	250	3625	280	4060	3000	600
2.5MB - 19	19.3	1.17	250	3625	280	4060	3000	600
2.5MB - 22	22.2	1.35	250	3625	280	4060	3000	500
2.5MB - 25	25.2	1.53	250	3625	280	4060	3000	500
2.5MB - 28	27.6	1.68	250	3625	280	4060	3000	500
2.5MB - 32	32.4	1.97	230	3330	250	3625	3000	500
2.5MB - 38	38.1	2.32	200	2900	220	3190	2750	400
2.5MB - 44	44.2	2.69	170	2465	190	2755	2500	400

GROUP 3 - E SERIES	cm ³ /rev	cu.in/rev	bar	psi	bar	psi	rpm	
3ME - 27	27	1.65	250	3625	280	4060	3000	600
3ME - 33	33.5	2.04	250	3625	280	4060	3000	600
3ME - 38	38.7	2.36	250	3625	280	4060	2750	500
3ME - 46	46.9	2.86	250	3625	270	3915	2750	500
3ME - 55	54.1	3.3	220	3190	240	3480	2500	400
3ME - 65	63.1	3.85	200	2900	220	3190	2500	400
3ME - 75	73.4	4.48	180	2610	200	2900	2500	400

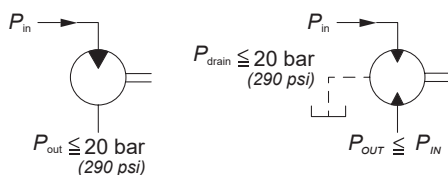

The Motors are equipped with HPD shaft seal (20bar), on request is available also for motor with outrigger bearing. Max drain pressure is influenced by rotational speed of the unit.

E0.100.0821.02.00IM03



INDEX

Shafts And Flanges Combination	153
Assembling Dimensions And Working Conditions.....	154
Flanged And Threaded Ports.....	155
Drive Shafts	156
Mounting Flanges	157
Outrigger Bearing	159
Rear Covers	162
Venting Valve For Double Step Of Speed	164
Electric Unloading Valve.....	165
Fan Drive	166
Performance Curves.....	167
How To Order Single Motors	171









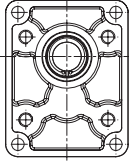
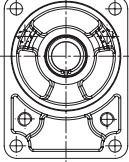

Final revised edition - February 2019

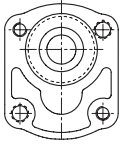
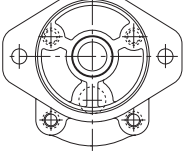
The data in this catalogue refers to the standard product.

The policy of Salami S.p.A. consists of a continuous improvement of its products. It reserves the right to change the specifications of the different products whenever necessary and without giving prior information.

If any doubts, please contact our sales department.

SHAFTS AND FLANGES COMBINATION

2ME					
	CODE P1 European standard	CODE B1 German standard	CODE B2-B3 German standard	CODE B4-B5 German standard	CODE S2-S6 SAE A 2 Bolts
 CODE 25 - Tapered 1:5		25B1		25B4 25B5	
 CODE 28 - Tapered 1:8	28P1				
 CODE 62 - DIN 5482 splined 9T	62P1	62B1	62B2 62B3	62B4 62B5	
 CODE 03 - Tang drive for electric motors			03B2 03B3		
 CODE 52 - SAE A splined 9T					52S2
 CODE 54 - SAE A splined 11T					54S2
 CODE 85 - SAE A parallel shaft Ø19.05					85S2
 CODE 82 - SAE A parallel shaft Ø15.87	82P1				82S2

Note: other versions available, see shafts and flanges information.

EO.120.0219.02.001M04

Displacements up to 1.58 cu.in./rev
Pressure up to 4060 psi

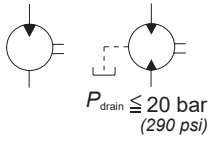

GEAR MOTORS

Displacements up to 25.8 cm³/rev
Pressure up to 280 bar

ASSEMBLING DIMENSIONS AND WORKING CONDITIONS

Type		4.5	6.5	8.3	10.5*	11.3	12.5*	13.8	16	19	22.5	26
Displacement	cm ³ /rev	4.6	6.5	8.2	10.6	11.5	12.7	13.8	16.6	19.4	22.9	25.8
	cu.in./rev	0.27	0.40	0.50	0.65	0.68	0.77	0.84	1.01	1.15	1.37	1.58
Dimension A	mm	47.1	49.95	52.8	56.3	59.7		63.5	67.5	75.6	81	86.8
	in	1.83	1.97	2.07	2.22	2.35		2.5	2.65	2.97	3.19	3.42
Dimension C	mm	23.55	25	26.4	28.15	29.75		31.75	33.75	37.80	40.5	43.4
	in	0.93	0.98	1.04	1.11	1.17		1.25	1.33	1.49	1.59	1.71
Max continuous pressure	P ¹	bar	250	250	250	250	250	250	250	220	200	180
		psi	3625	3625	3625	3625	3625	3625	3625	3625	3190	2900
Max starting pressure	P ²	bar	280	280	280	280	280	280	280	280	240	220
		psi	4060	4060	4060	4060	4060	4060	4060	4060	3480	3190
Max speed	rpm	4000	4000	3600	3500	3500	3400	3400	3200	3200	3000	2850
Min speed	rpm	600	600	500	500	500	500	500	450	450	450	450
Weight	kg	3.10	3.50	3.60	3.70	3.75	3.78	3.86	4.00	4.18	4.29	4.54
	lbs	6.83	7.72	7.94	8.16	8.27	8.33	8.51	8.82	9.22	9.46	10.1

*Available for quantity

For flanges code:

P1-B1-S2-S6, this dimension is 19 mm (0.75 in.)

B2-B3-B4-B5, this dimension is 16.5 mm (0.65 in.)

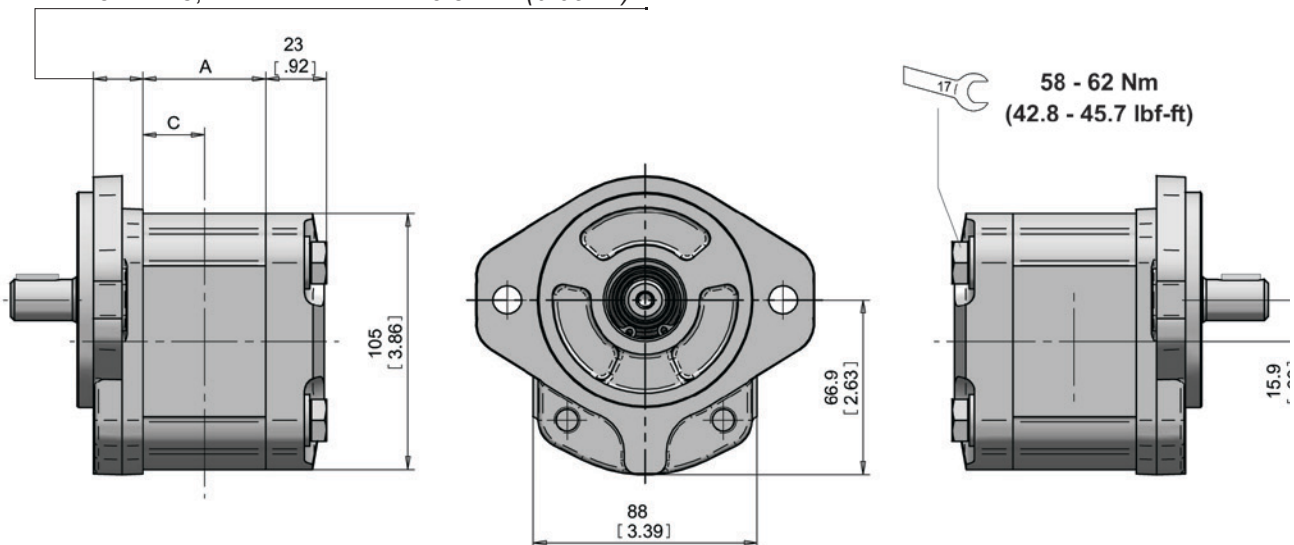

E0.120.0219.02.00IM04



FLANGED AND THREADED PORTS

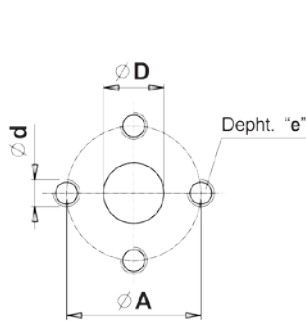

code P

Flanged ports
european standard

UNI-DIRECTIONAL MOTORS	TYPE	OUTLET				INLET			
		Ø D	Ø A	d	e	Ø D	Ø A	d	e
	From 4.5 to 8.3	13 (0.51")	30 (1.18")	M6	13 (0.51")	13 (0.51")	30 (1.18")	M6	13 (0.51")
	From 11.3 to 22.5	20 (0.78")	40 (1.56")	M8					
	26	25 (0.97")							



BI-DIRECTIONAL MOTORS	TYPE	OUTLET				INLET			
		Ø D	Ø A	d	e	Ø D	Ø A	d	e
	From 4.5 to 16	13 (0.51")	30 (1.18")	M6	13 (0.51")	13 (0.51")	30 (1.18")	M6	13 (0.51")
	From 19 to 26	20 (0.78")	40 (1.56")	M8		20 (0.78")	40 (1.56")	M8	

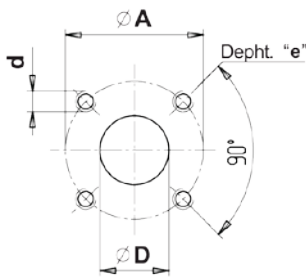

code B

Flanged ports
german standard

UNI-DIRECTIONAL MOTORS	TYPE	OUTLET				INLET			
		Ø D	Ø A	d	e	Ø D	Ø A	d	e
	From 4.5 to 22.5	20 (0.78")	40 (1.56")	M6	13 (0.51")	15 (0.59")	35 (1.38")	M6	13 (0.51")
	26	22 (0.87")							



BI-DIRECTIONAL MOTORS	TYPE	OUTLET				INLET			
		Ø D	Ø A	d	e	Ø D	Ø A	d	e
	From 4.5 to 16	15 (0.59")	35 (1.38")	M6	13 (0.51")	15 (0.59")	35 (1.38")	M6	13 (0.51")
	From 19 to 26	20 (0.78")	40 (1.56")			20 (0.78")	40 (1.56")		

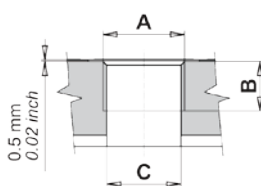

code G

Threaded ports
GAS (BSPP)

UNI-DIRECTIONAL MOTORS	TYPE	OUTLET			INLET		
		A	B	C	A	B	C
	From 4.5 to 26	G3/4	16 (0.62")	20 (0.78")	G1/2	14 (0.54")	13 (0.51")



BI-DIRECTIONAL MOTORS	TYPE	OUTLET			INLET		
		A	B	C	A	B	C
	From 4.5 to 16	G1/2	14 (0.54")	13 (0.51")	G1/2	14 (0.54")	13 (0.51")
	From 19 to 26	G3/4	16 (0.62")	20 (0.78")	G3/4	16 (0.62")	20 (0.78")

EO.120.0219.02.001M04



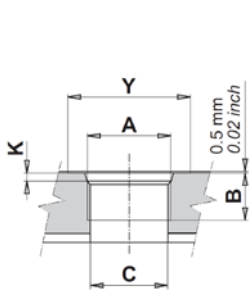

code R

Threaded ports
SAE (ODT)



TYPE	OUTLET					INLET				
	A	B	C	Y	K	A	B	C	Y	K
From 4.5 to 26	1-1/16-12 UN (SAE 12)	16 (0.62")	20 (0.78")	41 (1.61")	3.3 (0.12")	7/8 - 14 UNF (SAE10)	14 (0.54")	13 (0.51")	34 (1.32")	2.5 (0.10")

TYPE	OUTLET					INLET				
	A	B	C	Y	K	A	B	C	Y	K
From 4.5 to 16	7/8 - 14 UNF (SAE10)	14 (0.54")	13 (0.51")	34 (1.32")	2.5 (0.10")	7/8 - 14 UNF (SAE10)	14 (0.54")	13 (0.51")	34 (1.32")	2.5 (0.10")
From 19 to 26	1-1/16-12 UN (SAE 12)	16 (0.62")	20 (0.78")	41 (1.61")	3.3 (0.12")	1-1/16-12 UN (SAE 12)	16 (0.62")	20 (0.78")	41 (1.61")	3.3 (0.12")

DRIVE SHAFTS

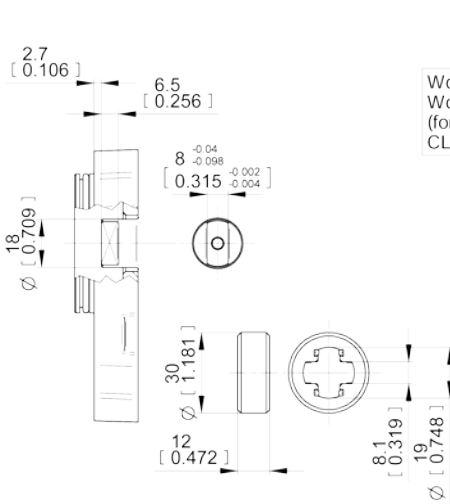

code 03 Max torque 72 Nm

Tang drive for electric motors
Without shaft seal

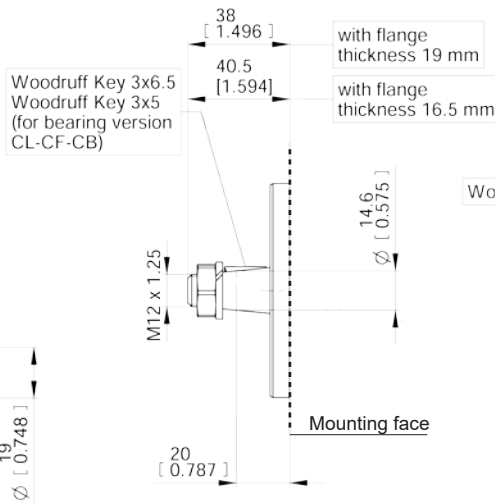

code 25 Max torque 130 Nm

Tapered 1:5

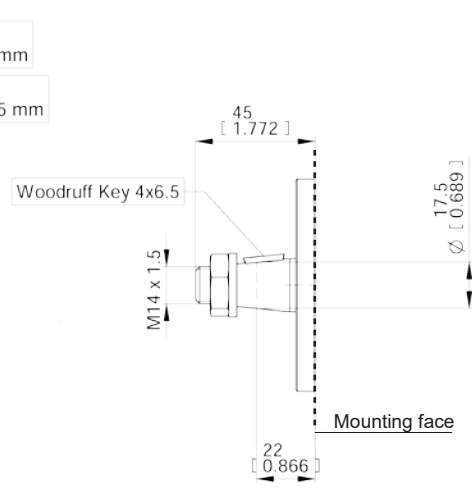

code 26 Max torque 100 Nm

Tapered 1:5 (only for CB)

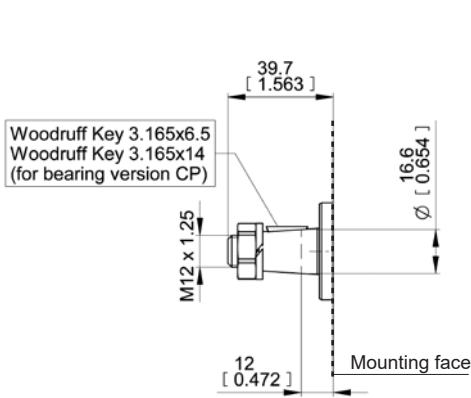

code 28 Max torque 130 Nm

Tapered 1:8

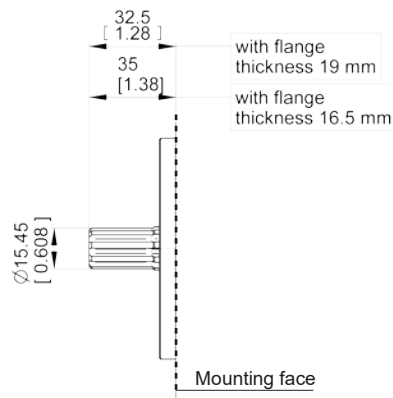

code 52 Max torque 100 Nm

SAE A 9T-16/32DP Ansi B92 1a 1976

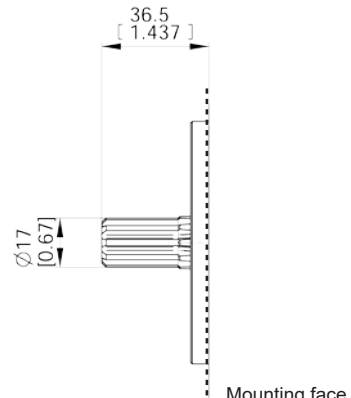

code 53 Max torque 125 Nm (1106 lbf in)

SAE 10T-16/32DP Ansi B92 1a 1976

E0.120.0219.02.00IM04



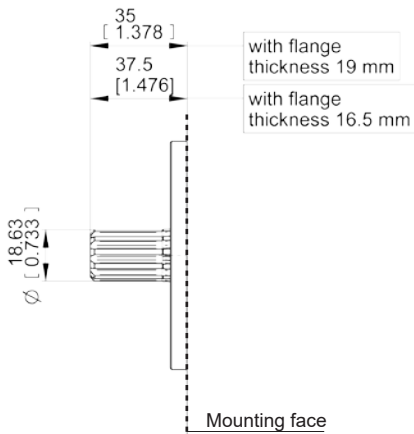

code 54 Max torque 150 Nm (1327 lbf in)
SAE A 11T-16/32DP Ansi B92 1a 1976

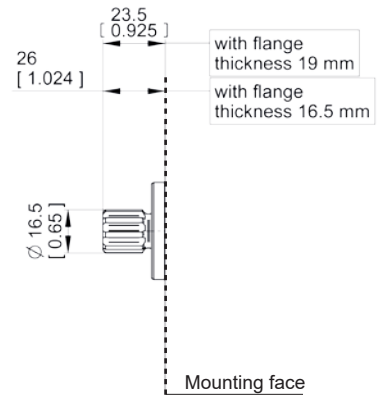

code 62 Max torque 120 Nm (1062 lbf in)
9 teeth DIN 5482 splined

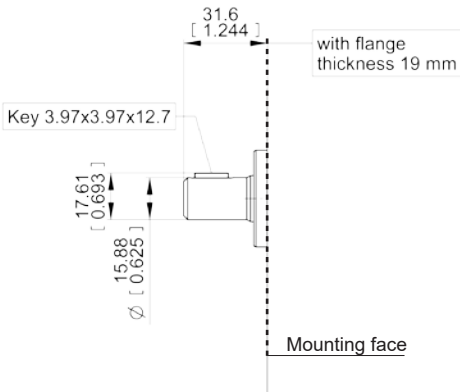

code 82 Max torque 70 Nm (620 lbf in)
5/8" SAE A parallel

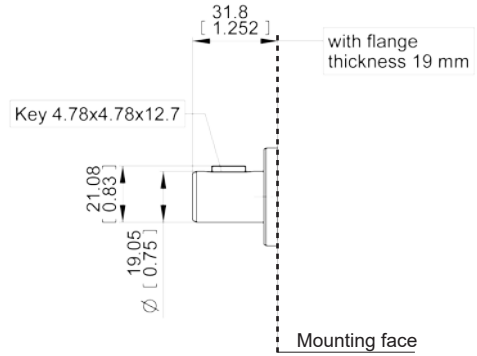

code 85 Max torque 130 Nm (1151 lbf in)
3/4" SAE A parallel

MOUNTING FLANGES

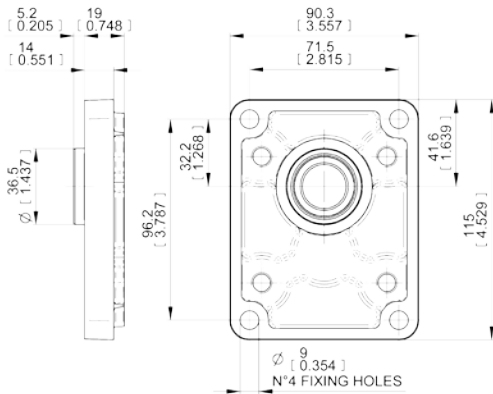

P1 European standard
With shaft code 28-62-82

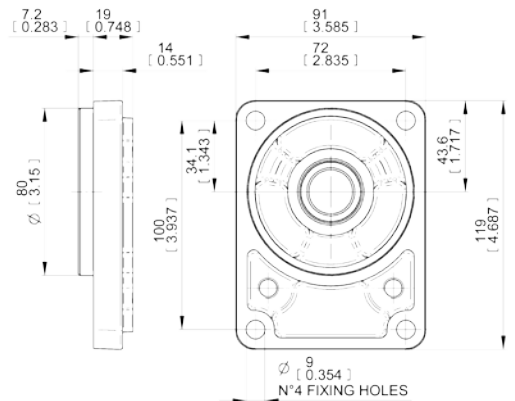

B1 German standard
With shaft code 25-62

EO.120.0219.02.001M04



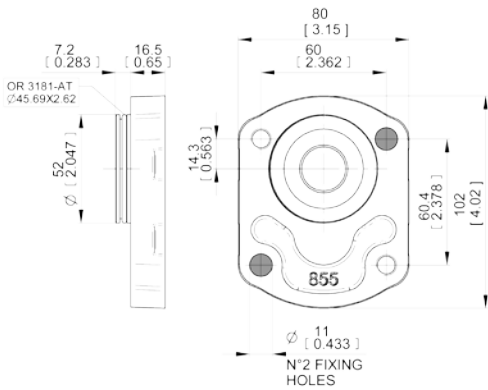

B2 German standard
With shaft code 03

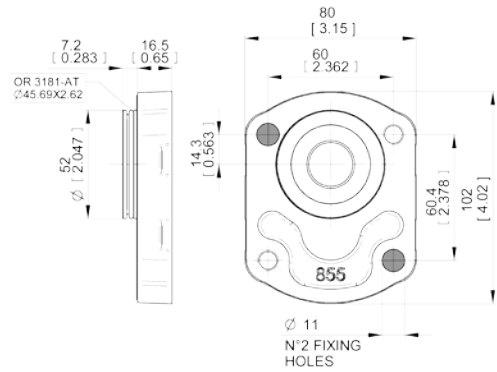

B3 German standard
With shaft code 03

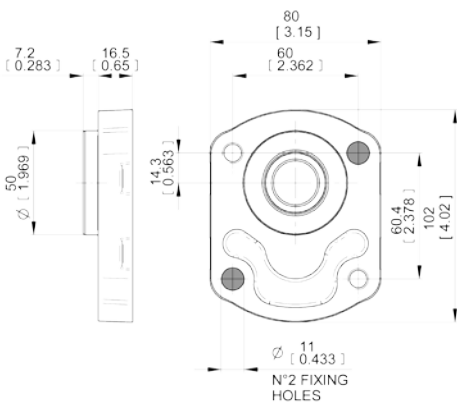

B4 German standard mounting flange
With shaft code 25-62

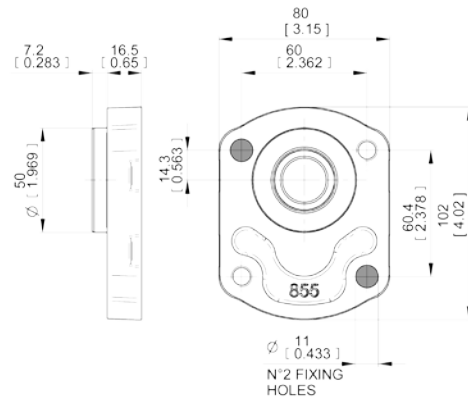

B5 German standard mounting flange
With shaft code 25-62

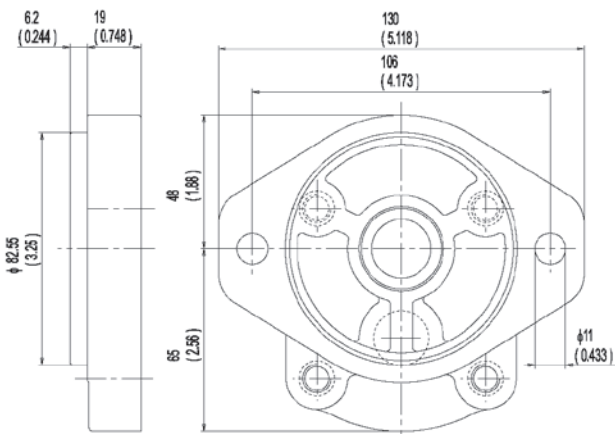

S2 SAE A
With shaft code 52-53-54-82-85

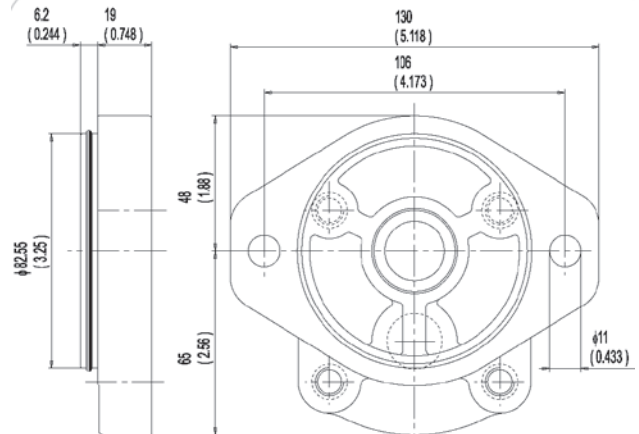

S6 SAE A 2 bolts
(with O-ring on the centering collar)
With shaft code 52-54-82-85

E0.120.0219.02.00IM04



OUTRIGGER BEARING

The following diagrams show radial load capability of the bearing.

Calculation according to ISO 281 at 10 cSt.

TYPE	H
4.5	47.1 (1.83")
6.5	49.95 (1.97")
8.3	52.8 (2.08")
10.5	56.3 (2.22")
11.3-12.5	59.7 (2.35")
13.8	63.5 (2.5")
16	67.5 (2.66")
19	75.6 (2.97")
22.5	81 (3.19")
26	86.6 (3.42")

L=Distance between mounting flange and radial force point of application.

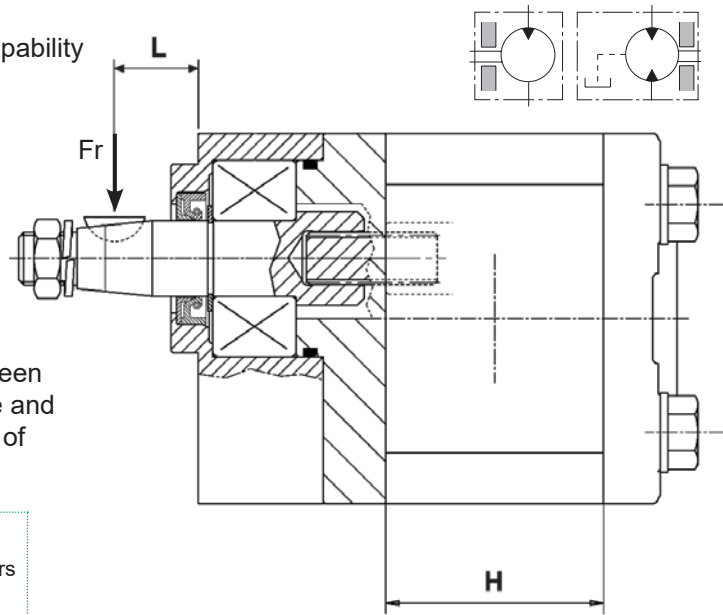

Example:
Fr = 1700 N
L = 7.5
Speed = 2000 rpm
→ Expected life: 1000 hrs

For Code CP-CB-CL-CS

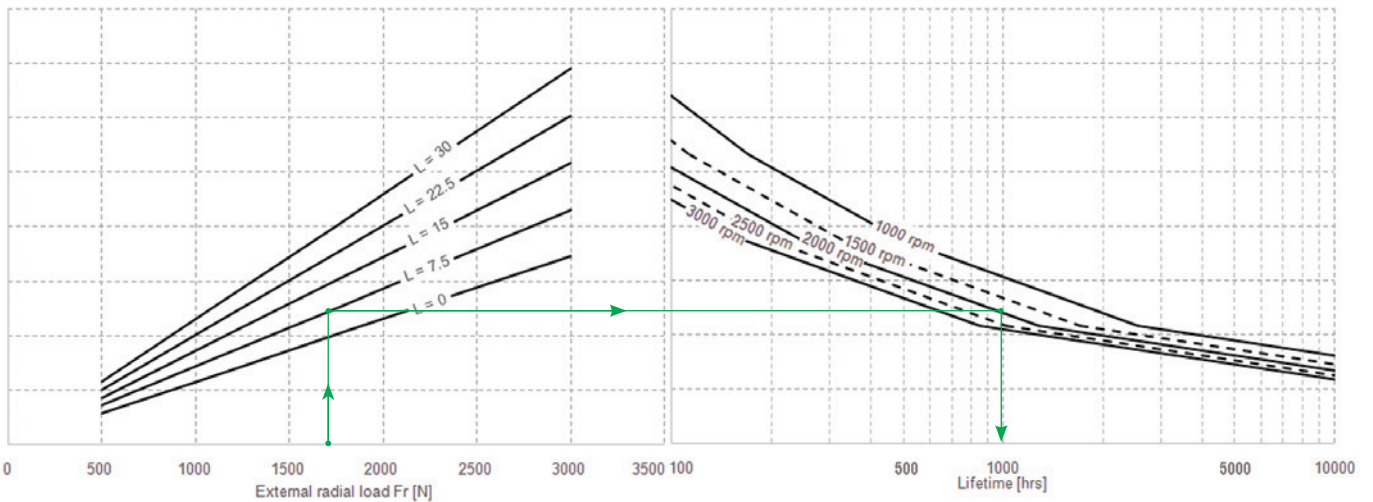

For Code CF

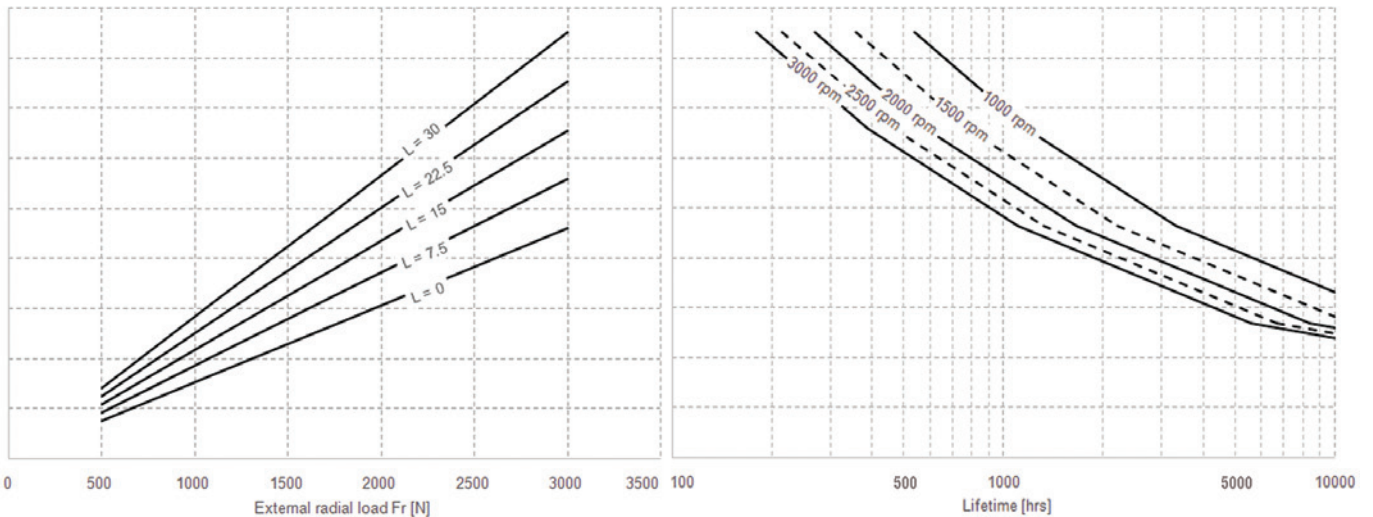

EO.120.0219.02.001M04



ALUMINIUM MOUNTING FLANGES
WITH BEARING

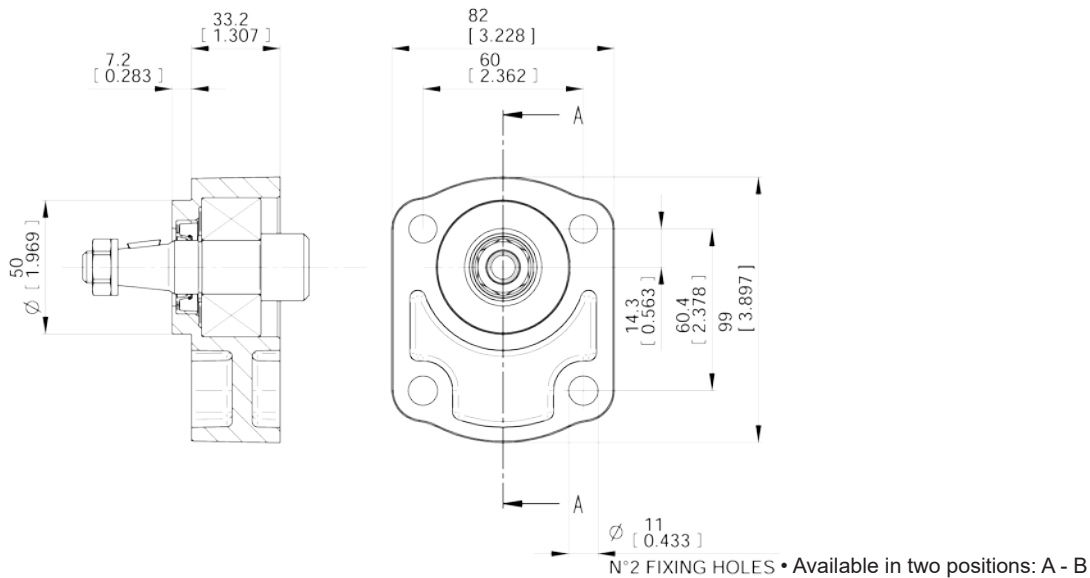

CL	For engine endothermic motors
With shaft code 25, 26 (see page 156)	

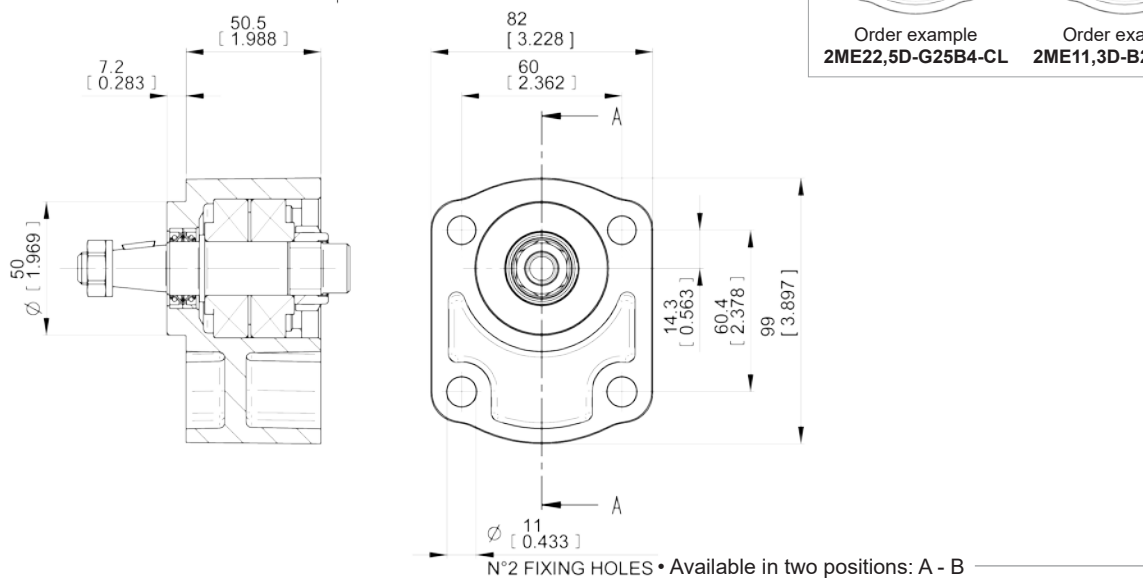
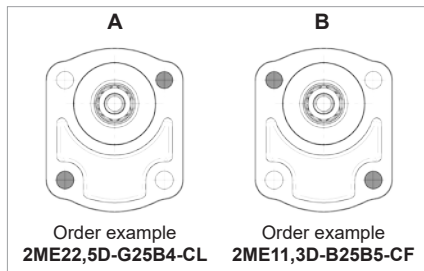

CF	For endothermic motors
With shaft code 25-26 (see page 156)	

E0.120.0219.02.00IM04



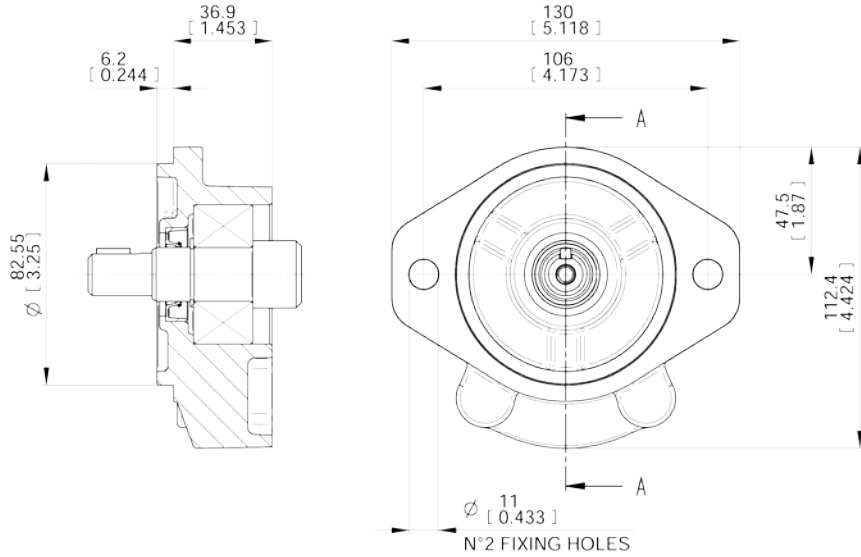

CS	SAE A
With shaft code 52-54-82-85 (see page 156-157)	

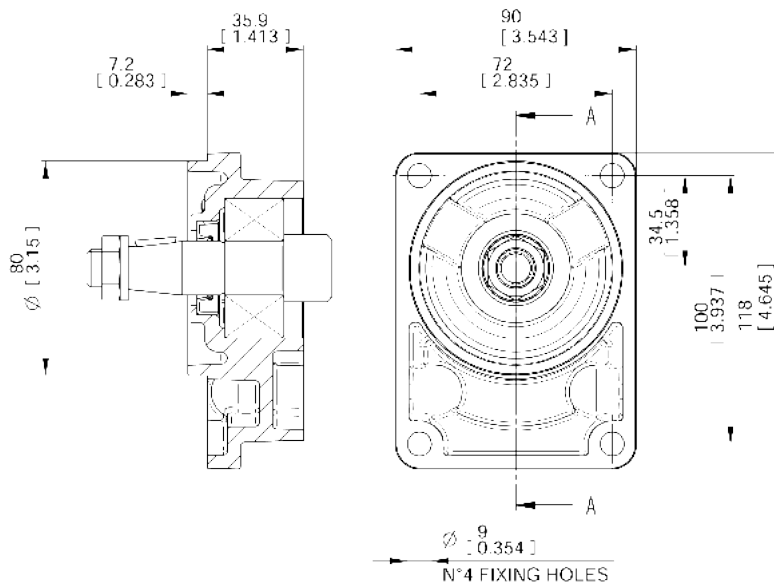

CB	German standard
With shaft code 25-26 (see page 156)	

EO.120.0219.02.001M04



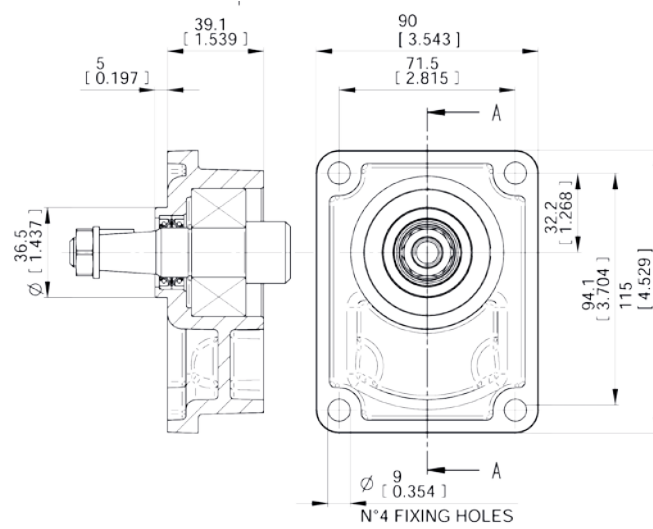

CP	European standard
With shaft code 28	

REAR COVERS

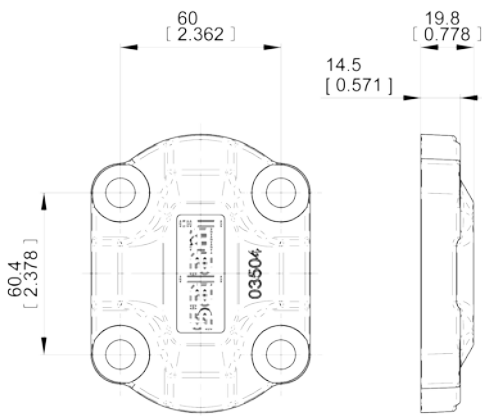

STANDARD REAR COVER

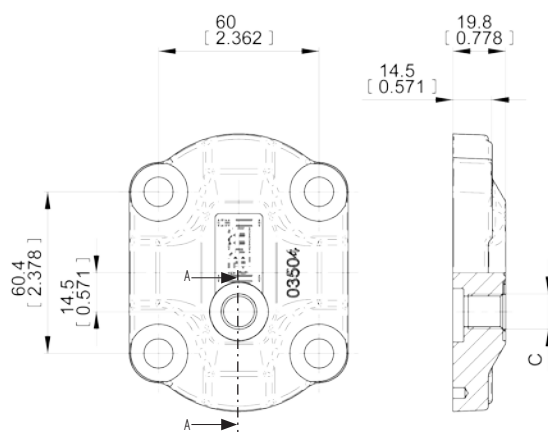

STANDARD REAR COVER WITH EXTERNAL DRAIN C FOR BIDIRECTIONAL MOTORS

code LD

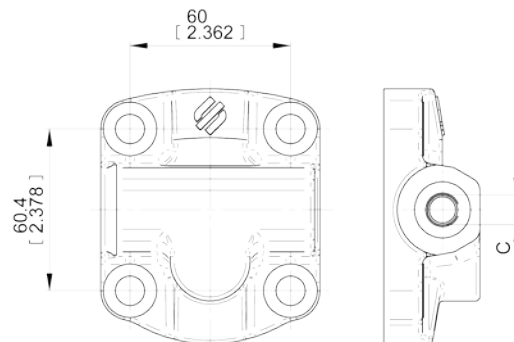
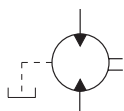

REAR COVER WITH LATERAL DRAIN

C
G1/4
7/16-20 UNF-2B (SAE4)

E0.120.0219.02.00IM04



code 1 REAR COVER WITH REAR PORTS

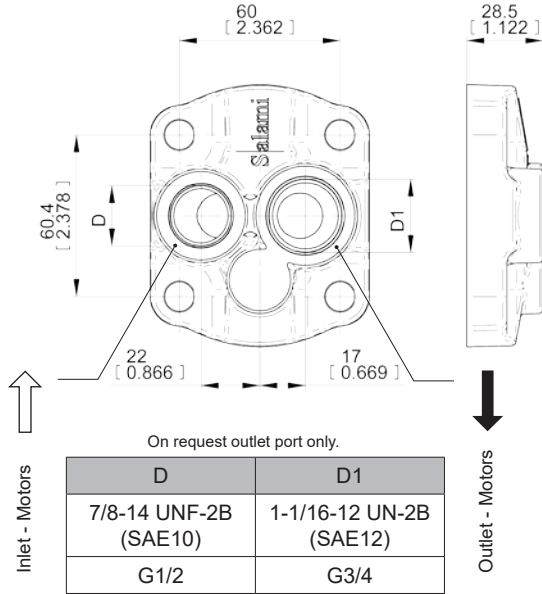

code 1 REAR COVER WITH REAR PORTS AND EXTERNAL DRAIN FOR BIDIRECTIONAL MOTORS

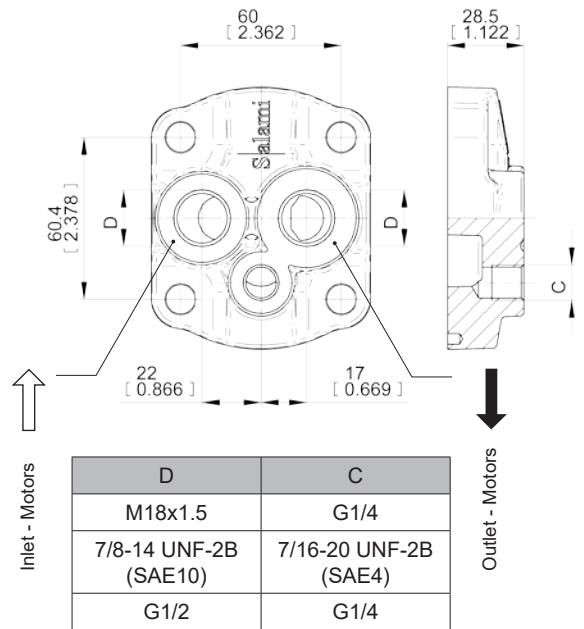

For rear ports if requested please advise type using.
For motors with threaded rear ports until 22 l/min delivery note.

REAR COVERS WITH VALVE

code VS INTERNAL DISCHARGE

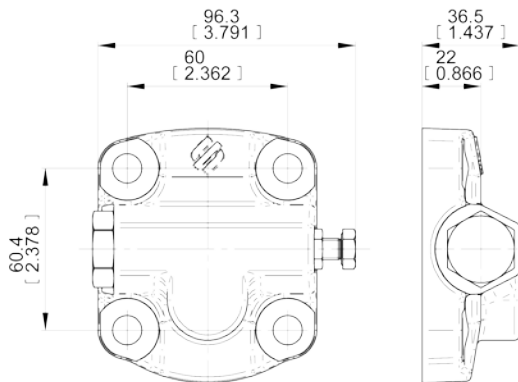

MAIN RELIEF VALVE setting ranges
30-60 bar
61-120 bar
121-170 bar
171-250 bar

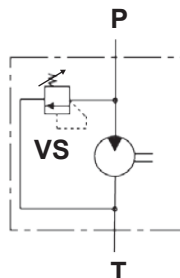

code VSE EXTERNAL DISCHARGE

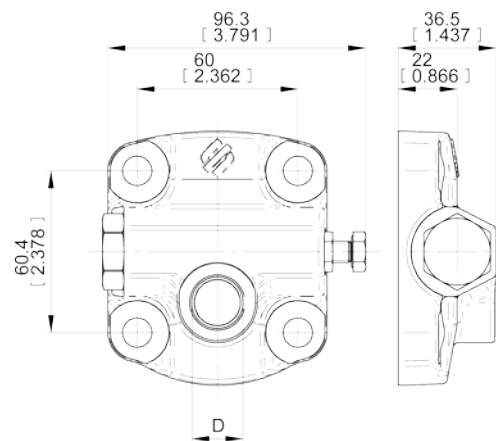

D (external discharge)
M18x1.5 (METRIC)
3/4-16 UNF-2B (SAE 8)
G3/8 (BSPP)

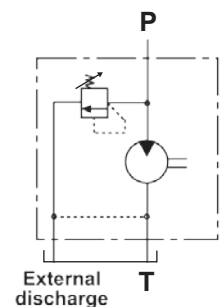

EO.120.0219.02.001M04



code VR ANTI-CAVITATION VALVE

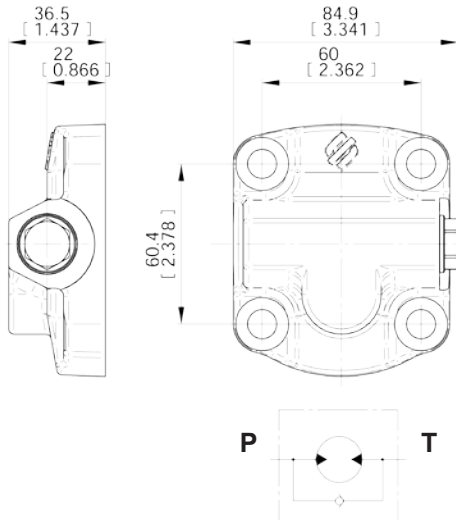

code IDV REAR COVERS WITH INTERNAL DRAIN

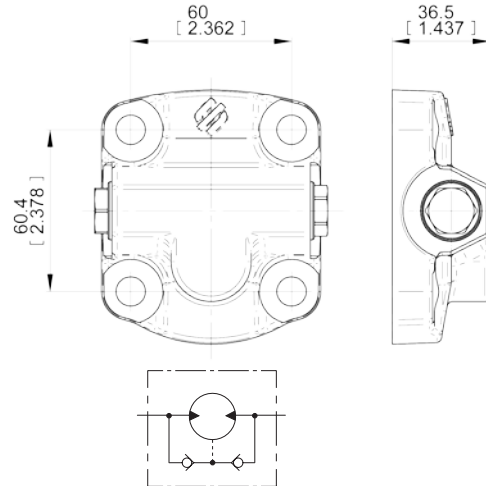

VENTING VALVE FOR DOUBLE STEP OF SPEED

code EPV

ELECTRIC RELIEF VALVE 2 - way with filter features:
VEI - 8I - 2A - 06 - NA - S1 - F - NSS
Coil 12V
Termination DIN 43650
Rated flow 30 L/min
Maximum operating pressure 210 bar

With this valve, we are able to fix a first step of speed (thanks to a calibrated orifice) when the electric venting valve is normally opened.

Energizing the valve you will have the full speed, in addition an overload and anti-cavitation valve protects the motor from peak of pressure and from reverse rotation caused by inertia.

Changing the calibrated orifice we are able to evaluate different cases in order to reach the customer's need.

C
G1/4
7/16-20 UNF-2B (SAE4)

Calibrated orifice in order to fix the speed

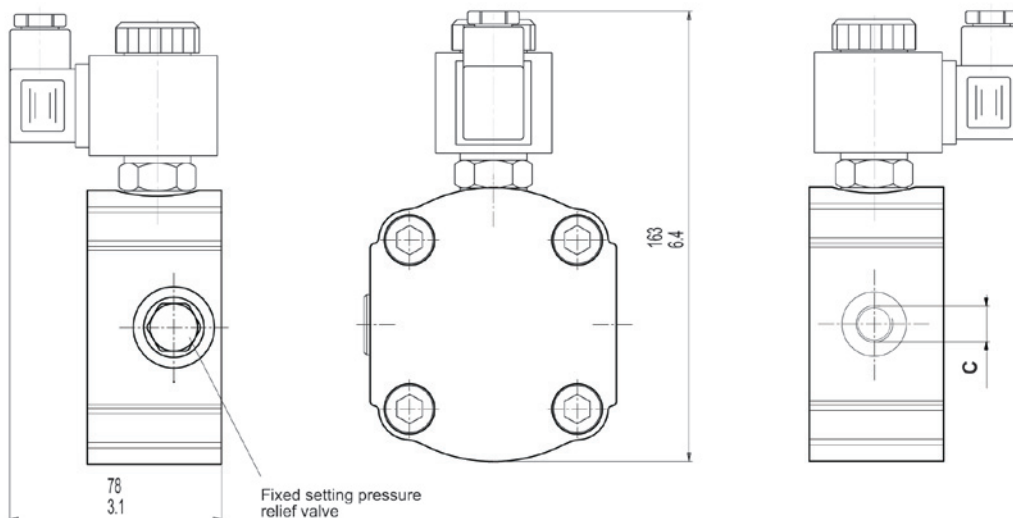
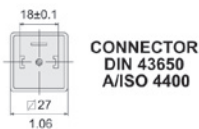
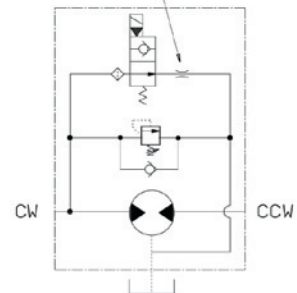

E0.120.0219.02.00IM04



ELECTRIC UNLOADING VALVE

code EV

EV1 - 12 Vcc
EV2 - 24 Vcc

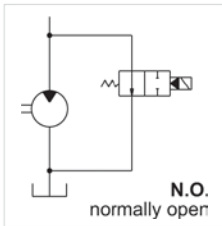

EV3 - 12 Vcc
EV4 - 24 Vcc

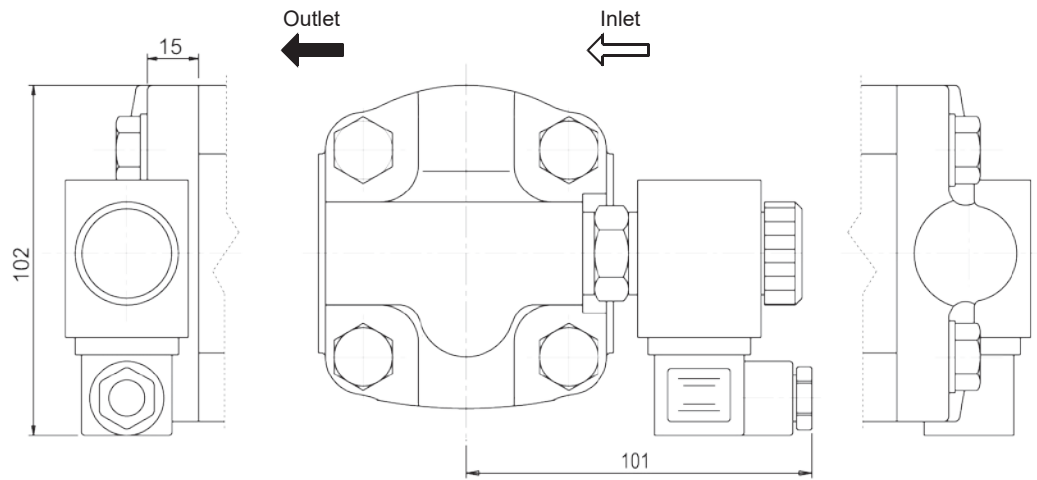
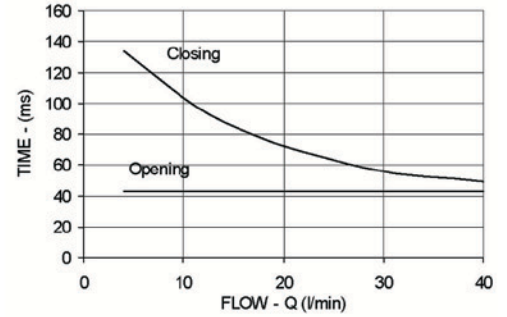
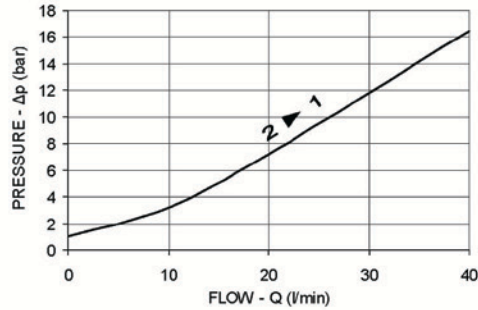
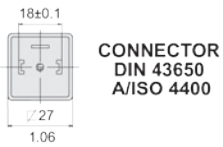
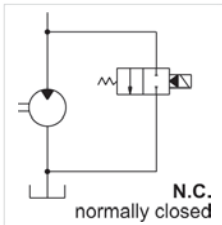

Cover with built-in relief and electric unloading valve

code EVS

EVS1 - 12 Vcc
EVS2 - 24 Vcc

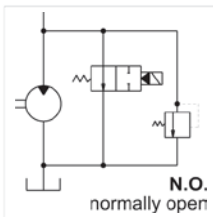

EVS3 - 12 Vcc
EVS4 - 24 Vcc

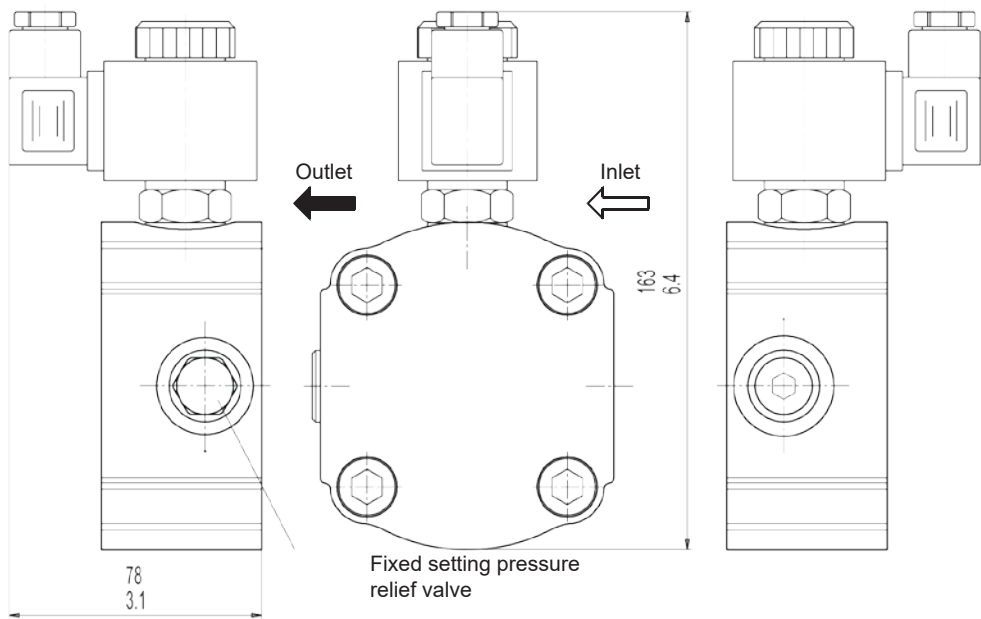
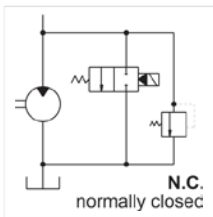

EO.120.0219.02.001M04



FAN DRIVE

Integrated manifold designed for fan drive systems with group 2 motors. The directional 4/2 electric valve and the proportional relief valve make the temperature regulation precise and the cooler's declogging efficient. Reduced dimensions, low weight and high pressure level are obtained thanks to a finite elements structural optimization of the casting.

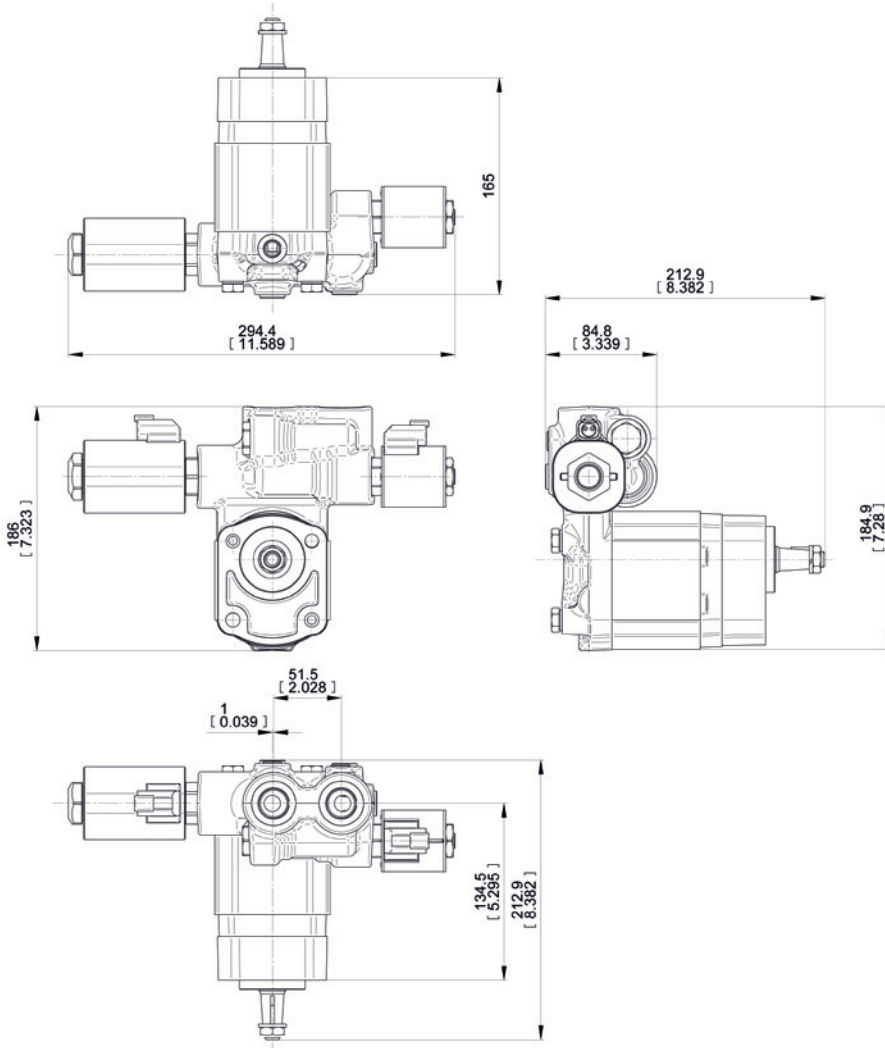

General Constructive Features

- Compact design.
- High pressure level thanks to a cast iron manifold.
- Flow rate up to 60 L/min - 16 US gpm.
- Low flow resistance.
- Proportional relief valve for a precise temperature regulation.
- Available with directional valve for an efficient declogging of the fan.
- Waterproof coils protection up to IP69K.
- Reduced weight thanks to a Finite Elements structural optimization.
- Protection against pressure and torque shocks.
- Maximum speed in case of electric power failure.

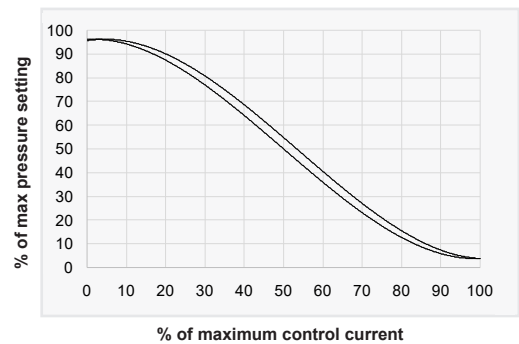
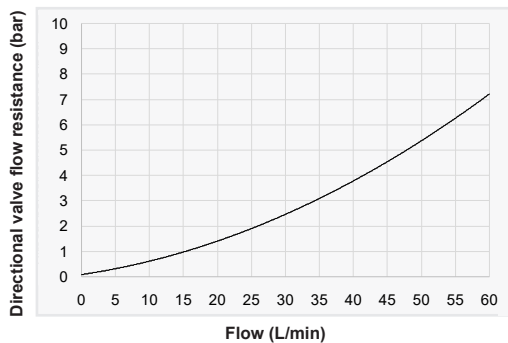
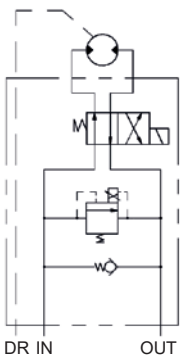

E0.120.0219.02.00IM04



PERFORMANCE CURVES

Performance curves carried out with oil viscosity at 21 cSt and oil temperature at 50°C

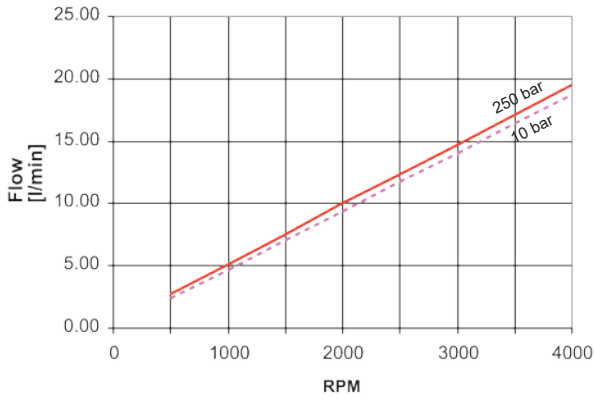

2ME - 4.5

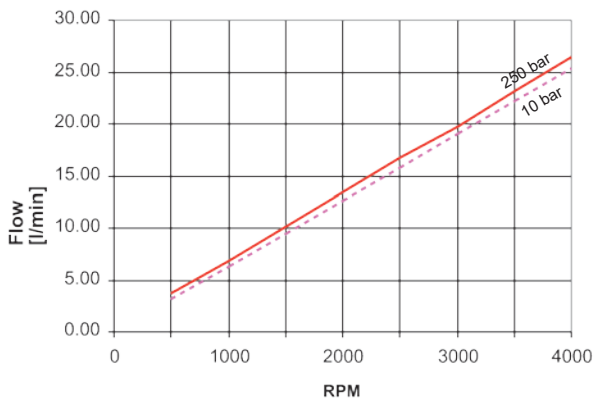
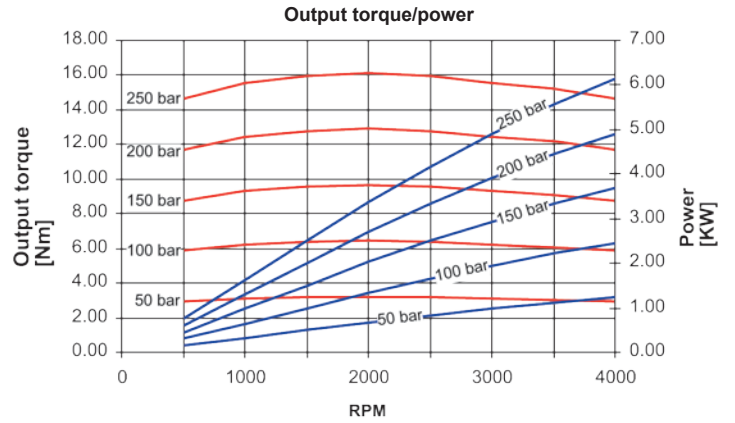

2ME - 6.5

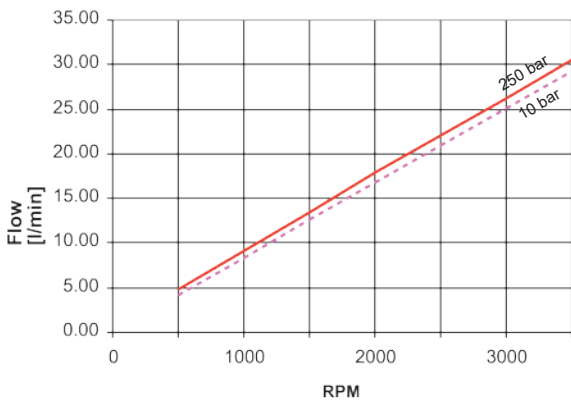
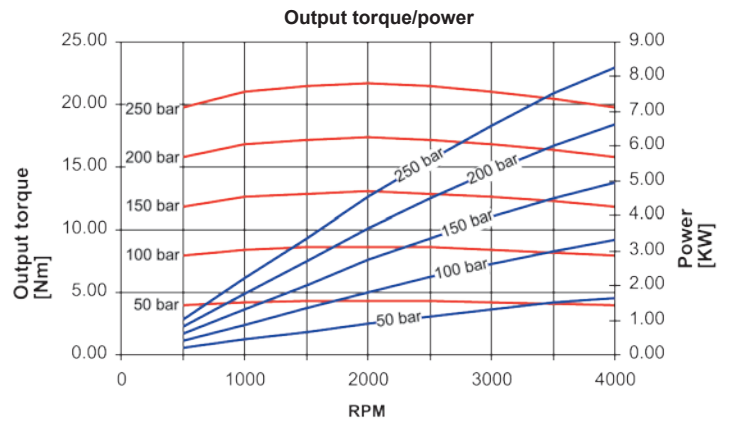

2ME - 8.3

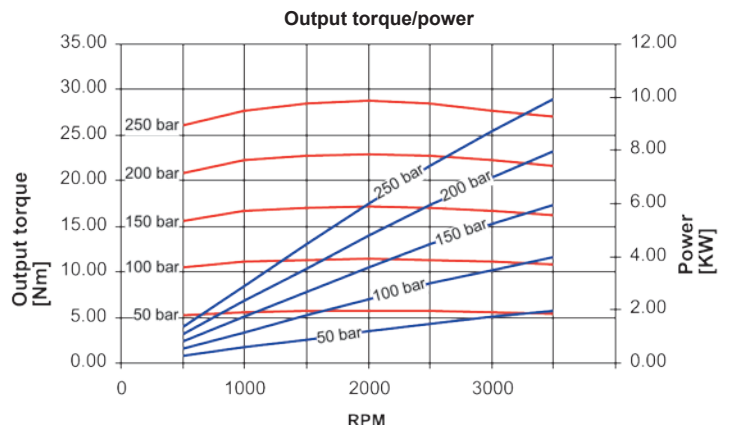

EO.120.0219.02.001M04



PERFORMANCE CURVES

Performance curves carried out with oil viscosity at 21 cSt and oil temperature at 50°C

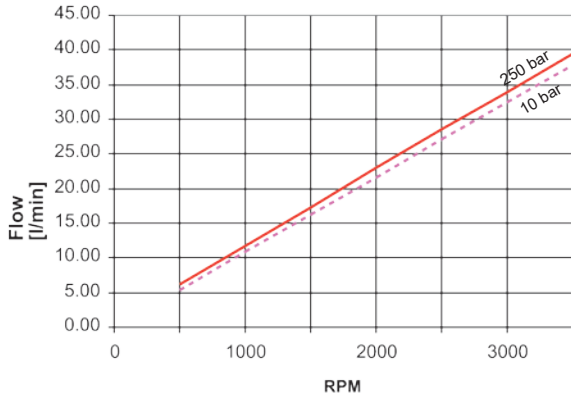

2ME - 10.5

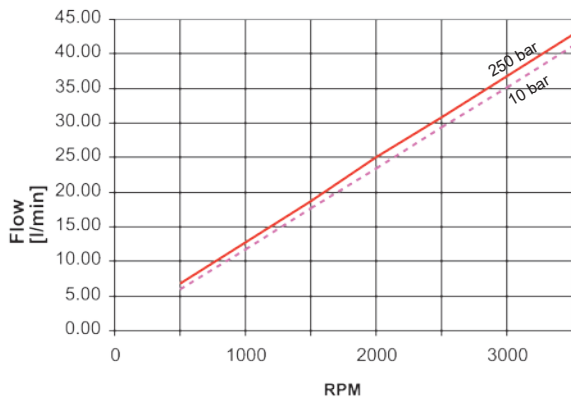
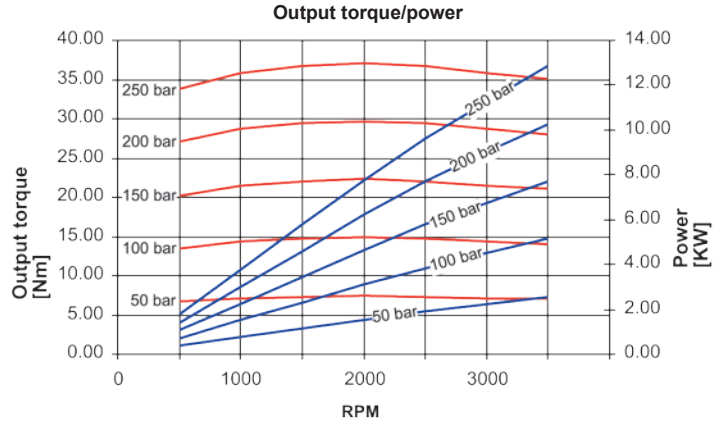

2ME - 11.3

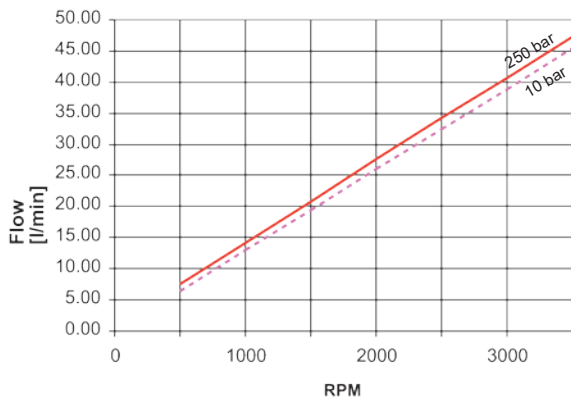
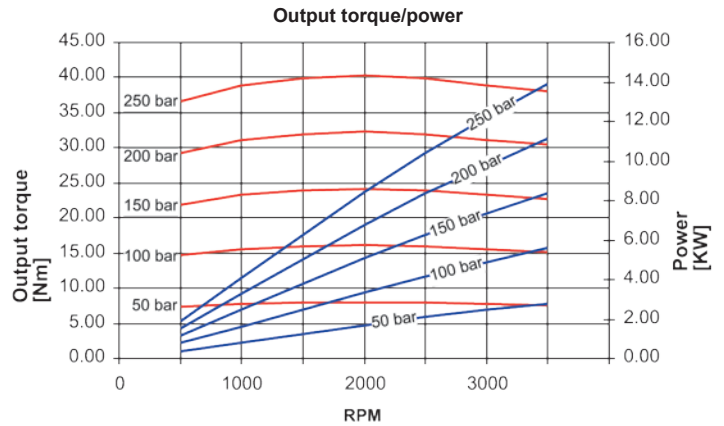

2ME - 12.5

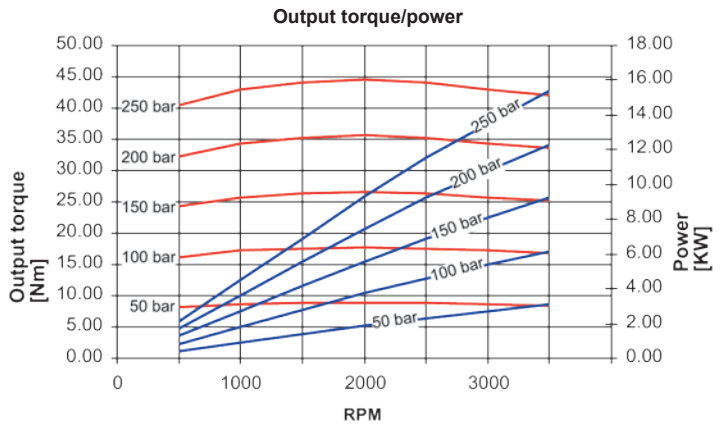

E0.120.0219.02.00IM04



PERFORMANCE CURVES

Performance curves carried out with oil viscosity at 21 cSt and oil temperature at 50°C

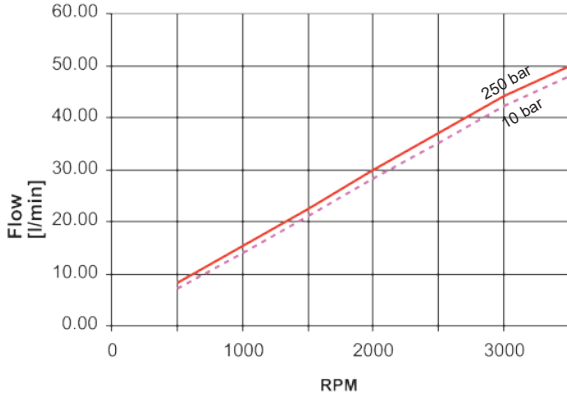

2ME - 13.8

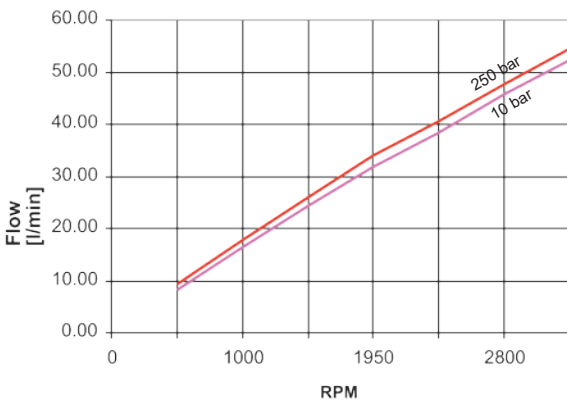
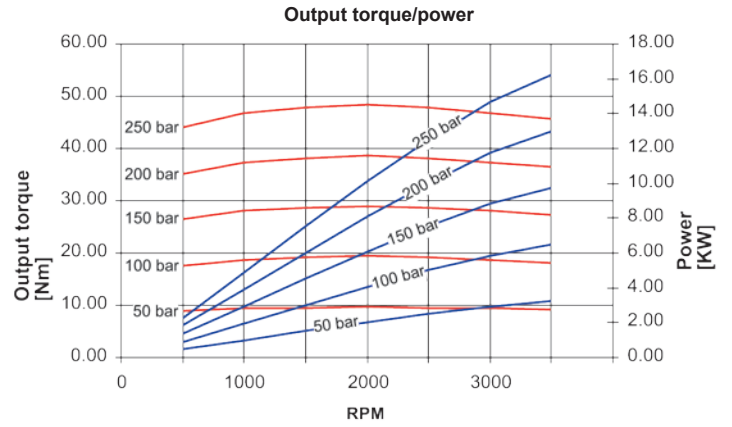

2ME - 16

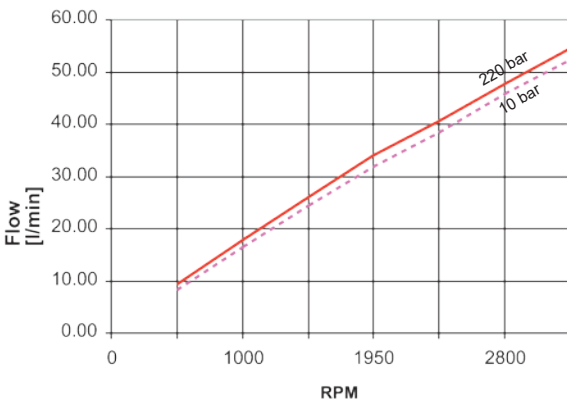
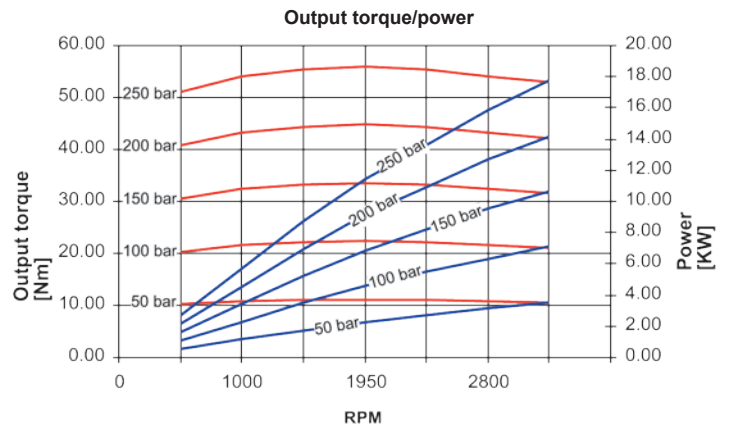

2ME - 19

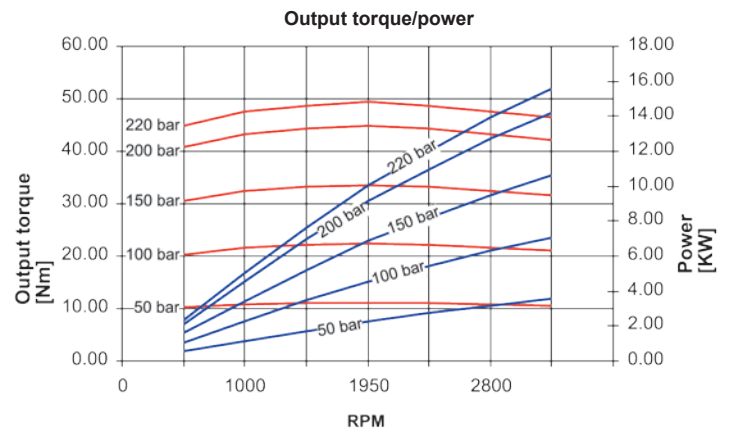

EO.120.0219.02.001M04



PERFORMANCE CURVES

Performance curves carried out with oil viscosity at 21 cSt and oil temperature at 50°C

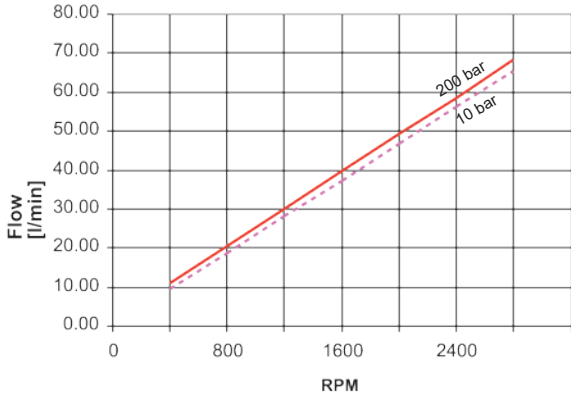

2ME - 22.5

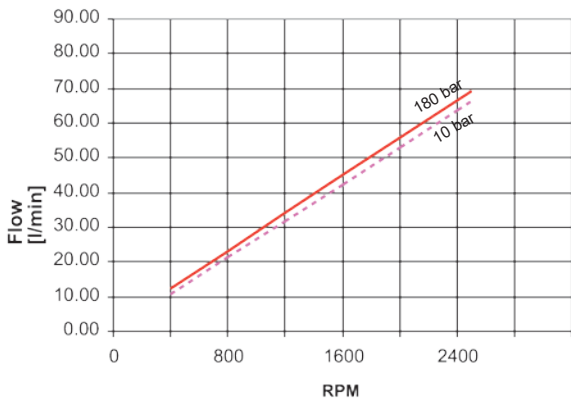
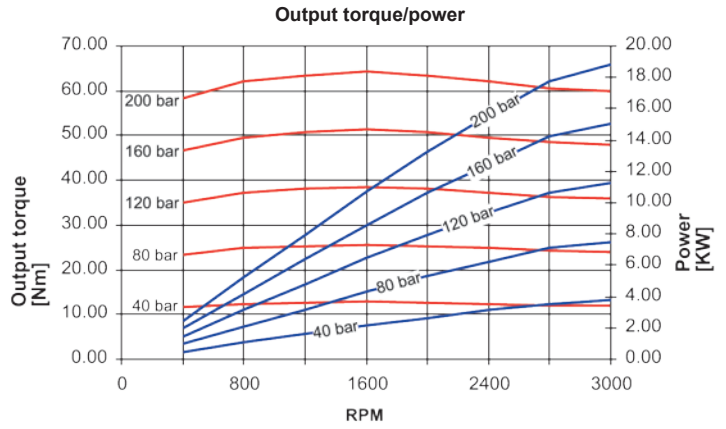

2ME - 26

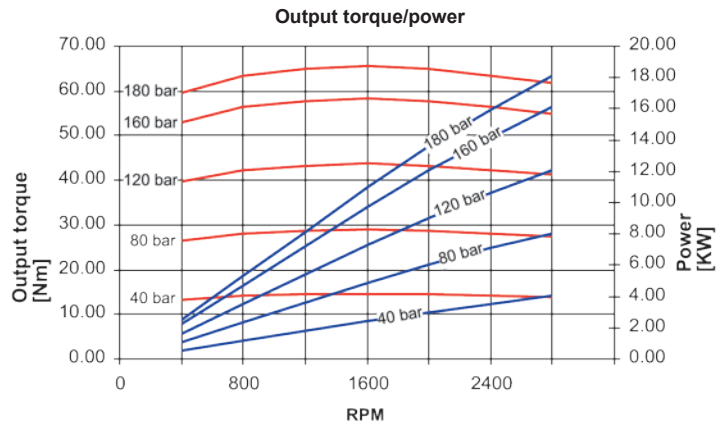

SINGLE MOTORS

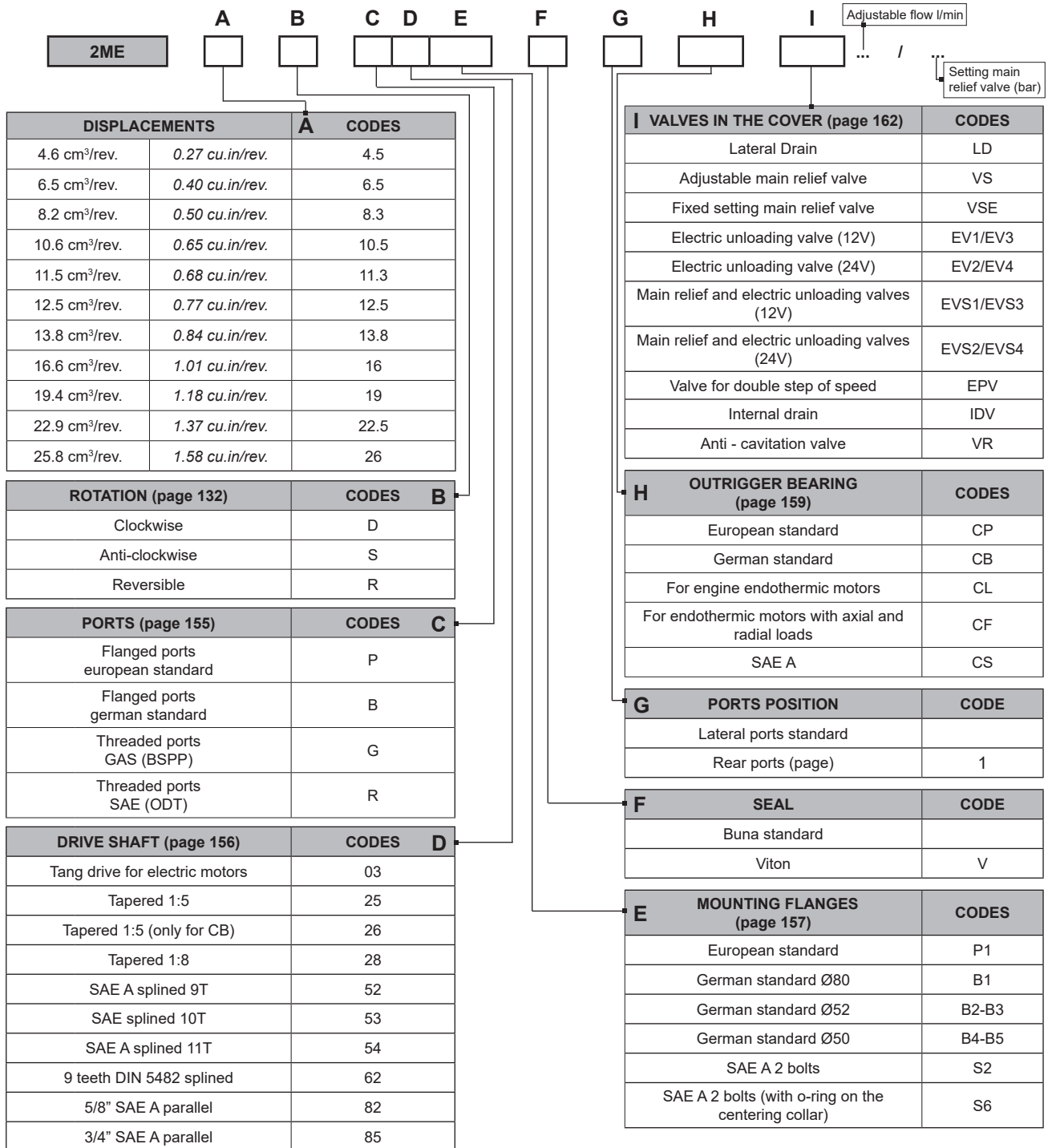

Order example: 2ME 19D, ports SAE (R), drive shaft (52), mounting flange (S2) with valve in the cover (VPS 12.5 l/min) and pressure relief valve setting 180 bar:
2ME19D-R52S2-VPS12.5/180

EO.120.0219.02.001M04



www.salami.it

You can find our most up to date “STANDARD SALES CONDITIONS” on our website.
Potete trovare le nostre più aggiornate “CONDIZIONI DI VENDITA STANDARD” sul nostro sito.

Ph. +39 059 387 411 - sales@salami.it



Watch our tutorials on our official youtube channels:

Salami Fluid Power
Salami Fluid Power World
Salami Fluid Power France
Salami Fluid Power España
Salami Fluid Power Deutsch

SALAMI S.P.A.

Via Emilia Ovest 1006
41123 Modena (Italy)
Ph. +39 059 387 411
F. +39 059 387 639
sales@salami.it

SALAMI ESPAÑA

Poligono Industrial Armenteres
C/Primer de Maig, 18, Nave 4
08980 San Feliu de Llobregat
Barcelona
Ph. +34-93-6665451
F. +34-93-6667826
info@salamispain.com

SALAMI FRANCE

22, rue Louis Saillant
69120 Valux en Velin
Lyon
Ph. +33-04-78809941
F. +33-04-78803669
e.pasian@salami.fr

SALAMI HYDRAULICS N.A INC

4630 Crossroads Park Drive
Liverpool
NY 13088 - USA
Ph. +1-315-295-2363
F. +1-315-295-2364
info@salamihydraulics.com