

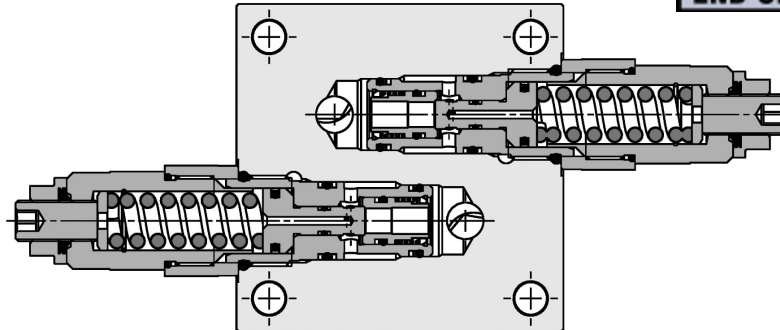

Valvola overcenter doppia incrociata, flangiabile su motori Oil-drive serie "MGL/MGT", con sblocco freno e valvola antiurto opzionale
Dual overcenter valve, flangeable on Oil-drive motors "MGL/MGT" series, brake release port, optional anti-shock valve

Rev.02-2016/09

**FINE PRODUZIONE
END OF PRODUCTION**

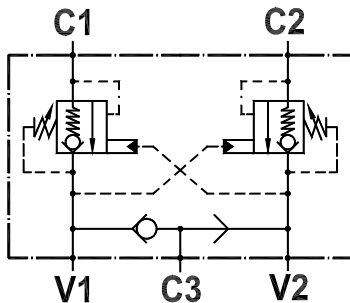

SPECIFICHE TECNICHE

Materiali: cartucce in acciaio zincato, parti interne in acciaio trattato termicamente. Corpo in lega di alluminio.

Portata max.: 60 l/min

Taratura max.: 350 bar

Pressione max: 250 bar

Rapporto di pilotaggio: 1 : 4 standard, a richiesta 1 : 8

Regolazione pressione: mediante vite

Campo di regolazione pressione: vedere pag. 02

Peso senza valvola antiurto: 1,900 Kg

Peso con valvola: 2,650 Kg

TECHNICAL SPECIFICATIONS

Materials: cartridges in steel zinc plated, internal parts in hardened steel. Body is in high strength aluminium alloy.

Rated flow: up to 60 l/min

Max. setting: 350 bar

Max. pressure: 250 bar

Pilot ratio: 1 : 4 std, 1 : 8 on request

Adjustment means: leakproof screw adjustment

Adjustable pressure range: see page 02

Weight without anti-shock valve: 1,900 Kg

Weight with anti-shock valve: 2,650 Kg

DIAGRAMMA PERDITE DI CARICO - PRESSURE DROP CURVES

Viscosità olio 24 mm²/sec. (3,5 °E)
Temperatura 50 °C

Oil viscosity 24 mm²/sec. (3,5 °E)
Temperature 50 °C

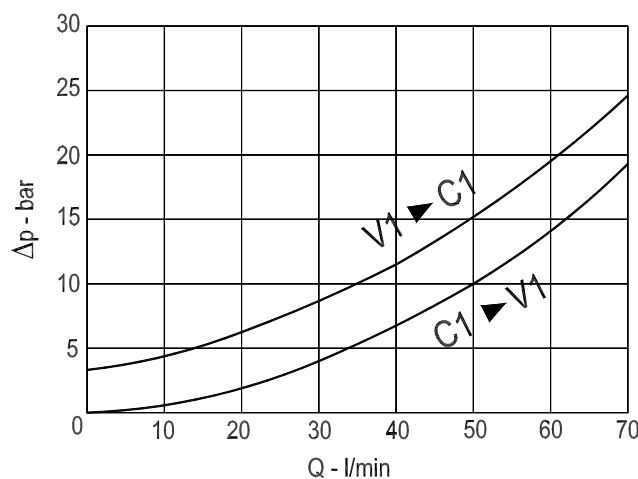

Valvola overcenter doppia incrociata, flangiabile su motori Oil-drive serie "MGL/MGT", con sblocco freno e valvola antiurto opzionale
Dual overcenter valve, flangeable on Oil-drive motors "MGL/MGT" series, brake release port, optional anti-shock valve

Rev.02-2016/09

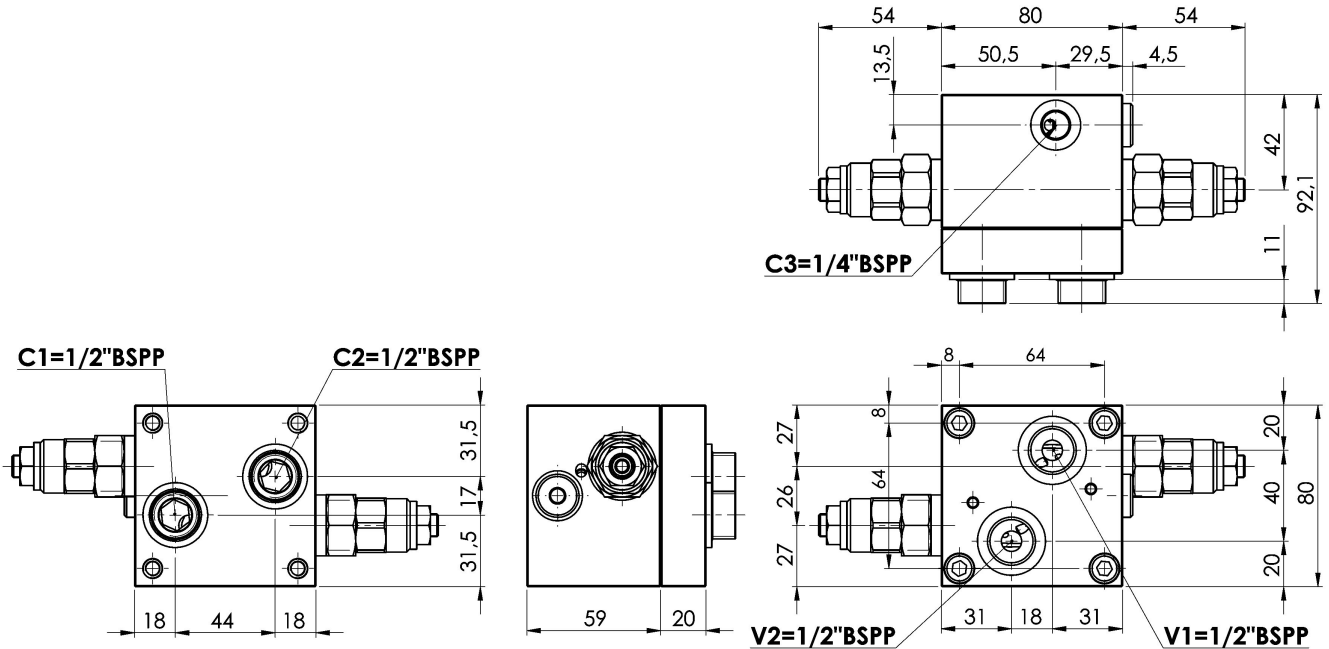

Versione con valvole anti-urto - version with anti-shock valves

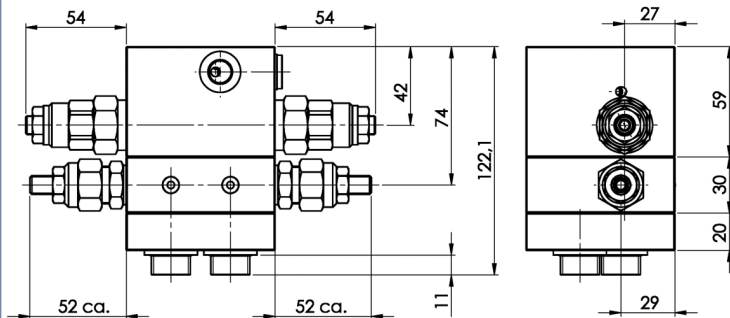

MOLLE - SPRINGS				*
Codice Code	Rapp. pil. Pilot ratio	Campo taratura min.-max. bar Adjustable pressure range bar	Increment. press. bar/giro vite Pressure increase bar/turn	Taratura standard bar Standard setting bar
20	1 : 4	60 - 220	50	170
20	1 : 8	60 - 220	50	170
35	1 : 4	100 - 350	110	280
35	1 : 8	100 - 350	110	280

ESEMPIO DI ORDINAZIONE - ORDERING CODE EXAMPLE

F P O 6 0 D V 0 1 1 / 2 U 2 0 B V M 0 5 *

* "20" / "35":
Campi di taratura pressione - Adjustable pressure

Rapporto di pilotaggio - Pilot ratio
* Omettere se standard - Omit if standard
B = 1 : 8

Guarnizioni - Seals:
V=Viton *
Omettere se BUNA-N
Omit if BUNA-N

Valvola di max., omettere se non richiesta
Relief valve, Omit if not requested
Campi di taratura pressione disponibili *
Available pressure range
"05"= 5 - 50 bar - "10"= 30 - 100 bar
"20"= 50 - 220 bar - "35"= 80 - 350 bar