

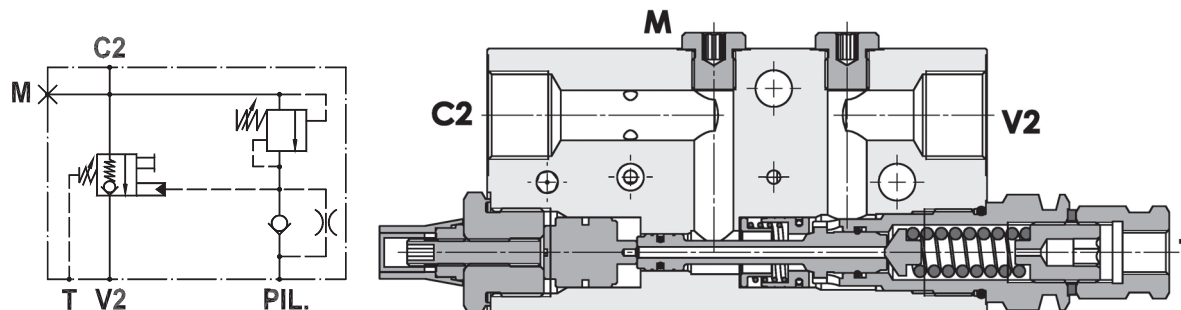

Valvola di blocco e controllo portata per bracci, montaggio in linea, versione destra
Flow check and metering valve for booms, line mounted, right version

Rev.03-2010/08

**SPECIFICHE TECNICHE**

Materiali: corpo in acciaio zincato. I componenti interni sono in acciaio trattato termicamente.

Portata max.: 150 l/min

Pressione max.: 420 bar

Regolazione pressione: mediante vite

Campo di regolazione pressione: vedere pag.02

Peso: 3.600 Kg

TECHNICAL SPECIFICATIONS

Materials: body is in steel zinc plated. Internal parts are in hardened steel.

Rated flow: up to 150 l/min

Max. setting: 420 bar

Adjustment means: leakproof screw adjustment

Adjustable pressure range: see page 02

Weight: 3.600 Kg

DIAGRAMMA PERDITE DI CARICO - PRESSURE DROP CURVES

Viscosità olio 24 mm²/sec. (3,5 °E)
 Temperatura 50 °C

Oil viscosity 24 mm²/sec. (3,5 °E)
 Temperature 50 °C

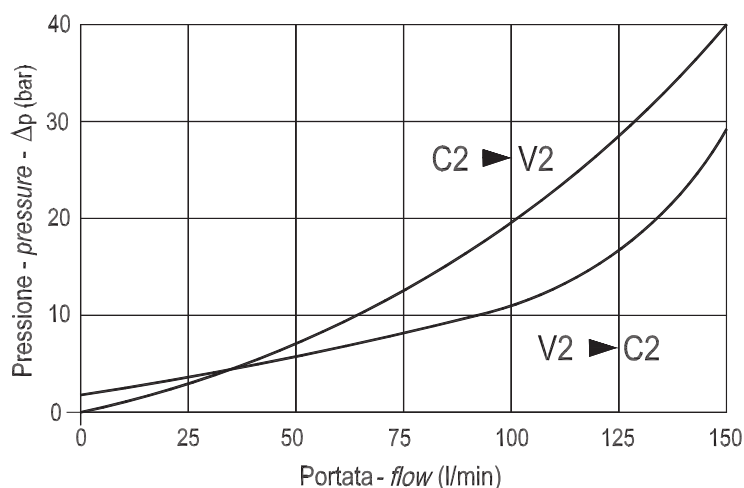

Valvola di blocco e controllo portata per bracci, montaggio in linea, versione destra
Flow check and metering valve for booms, line mounted, right version

Rev.03-2010/08

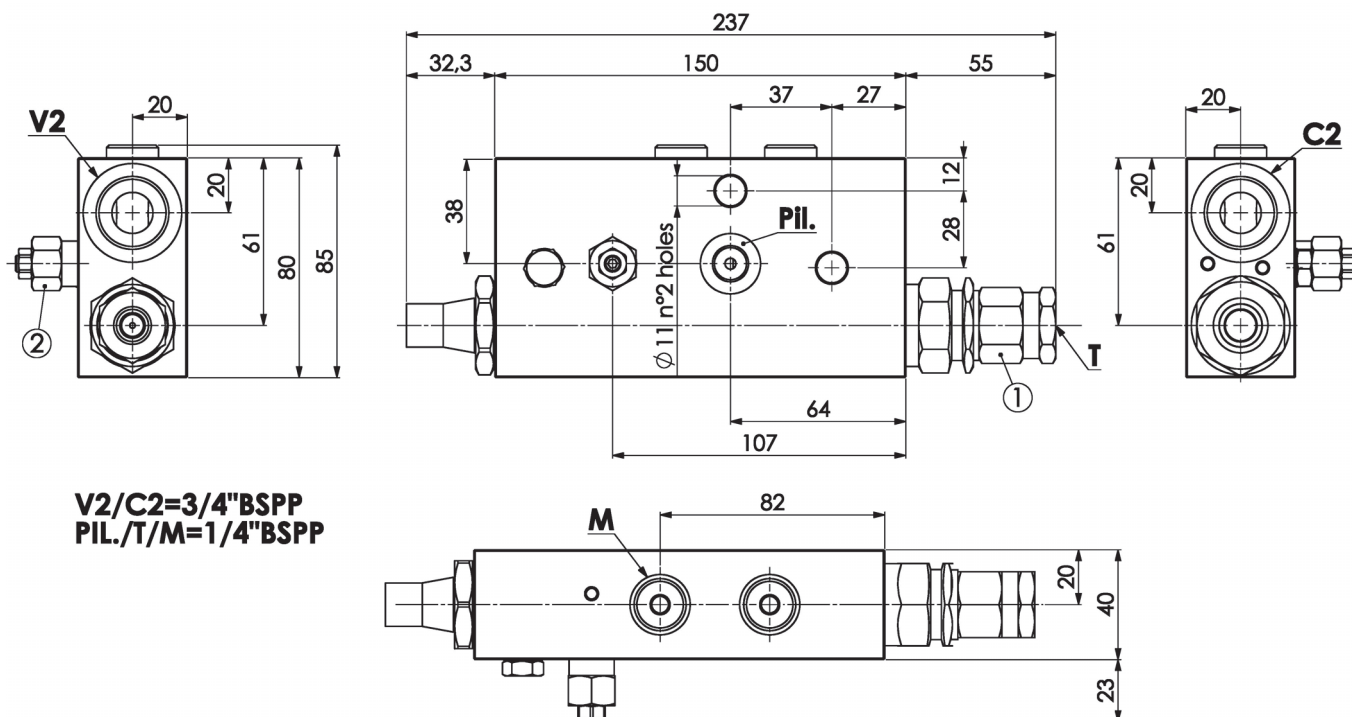

V2/C2=3/4\"/>

MOLLE VALVOLA (1) - SPRINGS VALVE (1)			
Codice Code	Campo taratura min.-max. bar Adjustable pressure range bar	Increment. press. bar/giro vite Pressure increase bar/turn	Taratura standard bar Standard setting bar
05	3.5 - 19.5	3.5	7.5

MOLLE VALVOLA (2) - SPRINGS VALVE (2)			
Codice Code	Campo taratura min.-max. bar Adjustable pressure range bar	Increment. press. bar/giro vite Pressure increase bar/turn	Taratura standard bar Standard setting bar
50	250 - 500	198	350

ESEMPIO DI ORDINAZIONE - ORDERING CODE EXAMPLE

F P E X C **1 5 0** **S** **3 / 4** **L** **D X** **0 5** **5 0**